

**GEOGRAPHY**  
**FORM ONE**  
**STUDYNOTES**

# CONCEPT OF GEOGRAPHY

## Meaning of Geography Phenomena

### The Meaning of the Term Geography

*Define the term geography*

The term Geography is a combination of two Greek words: Geo and Graphein. Geo means Earth and Graphein means to write, draw or describe. These two words together form Geographia, which means to draw, write about or describe the Earth. These meanings led to the development of the early definition of geography which referred to description of the Earth by words, maps and statistics and included both the physical earth and everything found on it such as plants, animals and people. Therefore, Geography is the study of the distribution and interrelationship of phenomena in relation to the Earth surface. Alternatively, Geography can be described as the study of the Earth and its environment.

## BRANCHES OF GEOGRAPHY

There are two branches of Geography, namely:

1. Physical Geography - mainly concerned with land formation processes, weather and climate.
2. Human and Economic Geography - involves the study of human activities on the Earth's surface

### Explain the inter-relationship between different geographical phenomena

Physical and human environments make up the two major geographical phenomena. The word phenomena refers to facts or circumstances observed, or observable within nature. Therefore, a geographical phenomenon is an occurrence or fact in the geographical science. There exists an interrelationship between Geography and other subjects; physical and human environments lead to geographical phenomenon within the two types of environment. There are a variety of other geographical phenomena that are interrelated, for example land resources provide soil that

support plants growth. Sun rays generate heat which lead to the evaporation of water; water vapour forms clouds and eventually rain is formed. Climate determines the types of plant and animal species that can survive in a particular geographical area and influences human population distribution. On the other hand, human activities can lead to modification of physical environments, for example soil degradation, land reclamation and forest conservation.

## Components of the Solar System

*Name the Components of the Solar System*

Below are the components that make up the solar system:

1. The Sun
2. Planets
3. Comets
4. Asteroids
5. Meteors; and
6. Satellites

## Importance of the Components of Solar System

*Describe the importance of the components of solar system*

Components of the Solar System are important because:

1. They produce heat and light potential for living organisms, for example the Sun
2. They provide habitat for humans and other living organisms, for example the Earth
3. They form craters which later become attractive sites for tourism activities, for example meteors which produce meteorites that fall on the Earth's surface and form craters

## The Sun

The Sun is a star.

## Dimension of the Sun in Relation to Other Space Bodies

*State the dimension of the sun in relation to other space bodies*

Dimension of the Sun relative to other Space Bodies: The diameter of the sun is 1.4 million kilometers

## Characteristics of the Sun

*Describe the characteristics of the sun*

The Sun is composed of approximately 75% Hydrogen, 23% Helium and 3% other elements. Therefore, the elements which make up the Earth comprise only a small fraction of the materials which form the Sun. These include Carbon, Iron, Oxygen, Silicon etc. The Sun is the only source of light and heat that the planet receives. The temperature of the Sun is estimated to be 20,000,000 degrees Centigrade.

## Solar Energy

### The Term Solar Energy

*Define the term solar energy*

Solar energy is the heat and light produced from the Sun. The Sun is the source of all energy on the Earth.

### Different Uses of Solar Energy

*Suggest different uses of solar energy*

Some of the different uses of Solar energy include:

1. Drying clothes, meat, fish, fruits and grains
2. Photosynthesis in growing plants to manufacture their own food
3. Generation of electricity
4. Formation of coal, gas and oil
5. Formation of clouds and rainfall through evaporation of water caused by the heat of the Sun

6. Giving power to small radios and running small telephone systems by using silicon solar batteries
7. Source of Vitamin D to human bodies as the bodies absorb Sunlight
8. For domestic purposes like cooking food, heating, water.

## How the Use of Solar Energy Promotes Environmental Conservation

*Explain how the use of solar energy promotes environmental conservation*

Utilization of Solar energy in manufacturing industries reduces the production of chlorine from industrially produced chlorofluorocarbon gases which cause depletion of the ozone layer. The depletion of the ozone layer causes global warming. Solar energy is used as an alternative source of energy, therefore reducing the depletion of forests for charcoal and firewood.

## How Solar Energy May Contribute to Emancipation of Women

*Explain how solar energy may contribute to emancipation of women*

### **REDUCED TIME BURDENS LEADING TO HIGHER-EARNING JOBS AND INCREASED ENTREPRENEURIAL OPPORTUNITIES**

Women are often disproportionately responsible for household duties. This is particularly acute in rural settings, where women spend considerable time on tasks such as collecting firewood for basic cooking, heating, and lighting needs. Access to energy allows for more efficient products—from those as basic as a solar lantern to those as advanced as a washing machine. These products can reduce the time burdens of domestic responsibilities and create time for more productive, formal engagement in the local economy outside the home. Empirical studies that have examined the impact of electrification on female labor rates in developing country settings reinforce this hypothesis.

### **IMPROVED BASELINE CONDITIONS LEADING TO GREATER ACCESS TO ECONOMIC OPPORTUNITIES**

There are a multitude of studies that demonstrate that improved access to electricity improves baseline living conditions for women. These studies show improvements to women's health through cleaner indoor air; better nutrition and food safety due to improved refrigeration; and improved health knowledge through better access to mass media and more time to read. Interior and exterior lighting in rural settings often means improved security for women, enabling greater mobility to engage in productive activities under safe conditions. Anecdotal evidence also shows improved education for girls as a result of access to electricity, although most empirical studies do not show gender-differentiated impacts. Improving these baseline conditions facilitates the ease by which women can participate in the local economy: Healthy, safe, and informed individuals are more apt to be productive.

## The Planets

### Planets in the Solar System

*Locate the planets in the solar system*

Planets are bodies that revolve around the Sun. Previously, they included Mercury, Venus, Earth, Mars, Jupiter, Saturn, Uranus, Neptune and Pluto. Pluto does not qualify to be a planet anymore as it is the smallest and does not revolve around the Sun. Therefore, there are currently officially only eight planets in our Solar System. The word 'Planet' originates from the Greek word 'Planetai' which means 'Wandering' as the planets seem to move about in the Sky as wandering stars. All planets revolve around the Sun in the same direction in orbits that are elliptical and nearly in the same plane. The time taken to complete an orbit depends on the distance from the Sun.

### Relative Distance of Planets from the Earth

*Show relative distance of planets from the earth*

### **How far is each planet from Earth?**

Usually when people ask this question, what they mean is "What is the distance between the orbit of Earth and the orbit of each planet?" or "What is the closest that each planet comes to Earth?" (These are essentially the same question, because the planets can't get any closer than their

orbital spacing allows.) You can compute this in a rough way by assuming that the orbits are circular and coplanar, and looking at the planet-to-Sun distance for each planet. Since the distances are so large, we usually express them in Astronomical Units (AU). (An AU is the average distance from Earth to the Sun, about 150 million kilometers or 93 million miles.) The table below lists the distance of each planet from the Sun in AU.

| Planet               | Average distance from Sun in AU |
|----------------------|---------------------------------|
| Mercury              | 0.39                            |
| Venus                | 0.72                            |
| Earth                | 1.00                            |
| Mars                 | 1.52                            |
| Jupiter              | 5.20                            |
| Saturn               | 9.58                            |
| Uranus               | 19.20                           |
| Neptune              | 30.05                           |
| Pluto (dwarf planet) | 39.48                           |

## Other bodies in the Solar System

### Characteristics of Comets, Asteroids, Meteors and Satellites

*Describe the characteristics of comets, asteroids, meteors and satellites*

**Comets** are objects with leading heads and bright tails in the Sky. Sometimes they can be seen at night. They are composed of ice crystals and fragments of solid matter. They have highly elongated orbits around the Sun. They can be seen from the Earth only when they come close to the Sun.

**Asteroids** are solid heavenly bodies revolving around the Sun. They are mostly found between the orbits of Mars and Jupiter. They are in thousands and the largest has a diameter of just less than 800 Kilometres. The bodies can only be seen with a telescope because they are very far away.

**Meteors** are pieces of hard matter falling from outer Space. They can be seen when they come close to the earth, at about 110-145 Kilometres, whereas as a result of friction with the atmosphere, they become hot and usually disintegrated. They fall on the Earth's surface as large boulders known as meteorites, or a meteor if it is one. These bodies are made of Nickel, Iron and Silica.

**Satellites** are the moons of the Planets and they can be defined as the small bodies which rotate on their axis and revolve around the Sun. There are only seven (7) planets which have satellites apart from 57 satellites in the Solar System. The number of satellites depends on the size and nature of the planet.

### Local Incidents Linked to Meteorites

*Narrate local incidents linked to meteorites*

There are two known meteorites in Tanzania. One is found in Mbozi district in Mbeya region and the other is in Malampaka in the Kwimba district in Mwanza region. These falling meteorites have resulted in the formation of craters.

### The Earth

The Earth is the only Planet among the planets in the Solar System that is known to support life. (Pluto does not qualify as a planet any more as it is the smallest and does not revolve around the sun). The Earth is made up of the atmosphere (air), hydrosphere (water bodies), the solid crust, molten materials and the biosphere (living organism). Water bodies cover about three quarters of the Earth's surface.

### The Shape of the Earth and its Evidence

*Describe the shape of the earth and its evidence*

There are many ways to prove that the earth is spherical. The following are some of them:



1.     **CIRCUMNAVIGATION OF THE EARTH:** The first voyage around the world by Ferdinand Magellan and his crew, from 1519 to 1522, proved beyond doubt that the earth is spherical. No traveller going round the world by land or sea has ever encountered an abrupt edge, over which he would fall. Modern air routes and ocean navigation are based on the assumption that the earth is round.
2.     **THE CIRCULAR HORIZON:** The distant horizon viewed from the deck of a ship at sea, or from a cliff on land is always and everywhere circular in shape. This circular horizon widens with increasing altitude and could only be seen on a spherical body.
3.     **SHIP'S VISIBILITY:** When a ship appears over the distant horizon, the top of the mast is seen first before the hull. In the same way, when it leaves harbour, its disappearance over the curved surface is equally gradual. If the earth were flat, the entire ship would be seen or obscured all at once.
4.     **SUNRISE AND SUNSET:** The sun rises and sets at different times in different places. As the earth rotates from west to east, places in the east see the sun earlier than those in the west. If the earth were flat, the whole world would have sunrise and sunset at the same time. But we know this is not so.
5.     **THE LUNAR ECLIPSE:** The shadow cast by the earth on the moon during a lunar eclipse is always circular. It takes the outline of an arc of a circle. Only a sphere can cast such a circular shadow.
6.     **PLANETARY BODIES ARE SPHERICAL:** All observations from telescopes reveal that the planetary bodies, the sun, moon, satellites and stars have circular outlines from whichever angle you see them. They are strictly spheres. Earth, by analogy, cannot be the only exception.
7.     **DRIVING POLES ON LEVEL GROUND ON A CURVED EARTH:** Engineers when driving poles of equal length at regular intervals on the ground have found they do not give a perfect horizontal level. The centre pole normally projects slightly above the poles at either end because of the curvature of the earth. Surveyors and field engineers therefore have to make certain corrections for this inevitable curvature, i.e. 12.6 cm to 1 km.
8.     **SPACE PHOTOGRAPHS:** Pictures taken from high altitudes by rockets and satellites show clearly the curved edge of the earth. This is perhaps the most convincing and the most up-to-date proof of the earth's sphericity.

## Earth's Movements

### Types of Earth's Movements

*Describe the types of earth's movements*

The Earth is in motion all the time. People cannot feel this motion because they move with it like all other planets. There are two types of movements of the earth, namely:

1. The rotation of the Earth on its own axis
2. The revolution of the Earth around the Sun

### The Term Rotation

*Describe the term rotation*

Rotation refers to the spinning of a body on its axis. The earth rotates or spins on its axis in an anti-clockwise direction, from West to East through 360° in 24 hours. Thus for every 15 degrees of rotation, the earth takes one hour which is the same as four minutes for every 1 degree.

An axis is an imaginary line joining the N (North) and S (South) poles through the center of the Earth.

**Note:** The rotation of the earth is very rapid although it is difficult to feel its motion. At the equator, every point of the earth's surface is traveling Eastwards at about 1600 Km per hour. At latitude 40 degrees, the speed is about 1280 Km per hr.

### Evidence to Prove that the Earth Rotates

*Give evidence to prove that the earth rotates*

Below is evidence that proves that the Earth rotates:

1. During the night, stars appear to move across the sky from West to East
2. If one travels in a fast moving vehicle, will notice trees and other objects on both sides of the road are moving fast in the opposite direction

3. Rising of the sun over the eastern horizon in the morning. This shows that the point of observation, that is south, is moving by rotation from West to East

4. Day and Night. During the Earth's rotations some regions face the sun while others do not face it. These regions facing the sun experience day time whereas the regions which are not facing the sun are in darkness (night). This proves that the earth is rotating.

## Significances of Earth's Rotation

*Explain the significances of earth's rotation*

Alternation of day and night: Rotation of the earth causes the sides of the earth which face the sun to experience daylight which is the day, whereas the side that is not facing the sun at that time will be in darkness (night).

1. The occurrence of tides in the ocean caused by gravitational forces of the moon and sun upon the rotation of the Earth

2. Deflection of winds and ocean current

3. Time difference between longitudes: The rotation is responsible for difference in time between different places on Earth. It causes the difference of one hour in every 15 degree interval between longitudes. The Earth rotates from West to East and takes 24 hours to complete one rotation. The difference in time is 4 minutes for each degree of longitude

## The Term Revolution

*Define the term revolution*

Revolution is defined as the movement of one body around another. The earth revolves around the sun in an elliptical orbit. Due to the elliptical shape of the earth orbit the sun is closer to the earth at one point of the year than at another.

The farthest (maximum distance) position from the sun in orbit of the earth is called aphelion while the nearest position of the earth to the Sun is known as perihelion.

## The Process of Revolution

*Explain the process of revolution*

The Earth is at aphelion each year on 4th July, when it is at the maximum distance of 152 million kilometers from the sun. The earth is at perihelion each year on 3rd January when it is at the minimum distance of 147 million kilometers.

The earth's revolution around the sun takes a year ( $365\frac{1}{4}$  days) therefore the speed of revolution is about 29.6 kilometers per second. A normal year has only 365 days. The remaining fraction of  $\frac{1}{4}$  day is added once in four years to make a leap year of 366 days.

## The Result of the Earth's Revolution Around the Sun

*Describe the result of the earth's revolution around the sun*

The result of the Earth's Revolution around the Sun:

1. The four seasons of the year; summer, autumn, winter and spring. A season is one of the distinct period into which the year may be divided. In the northern hemisphere the summer season months are May, June and July. Autumn months are August, September and October, winter months are November, December and January and spring months are February, March and April. In the southern hemisphere summer season months are November, December and January. Autumn months are February, March and April. Winter months are May, June and July and spring months are August, September and October. Equinox refers to the period when the sun is overhead at the equator.
2. Change in the position of the midday sun at different times of the year. As the earth revolves around the sun its position changes and makes it appear as if it is the sun moving.
3. Varying lengths of the day and night at different times of the year. The axis of the earth is inclined to its elliptical plane at a certain angle of 66.5 degrees. If the axis of the earth were vertical, the sun rays would be overhead at the Equator, thus all places on the earth would always experience 12 hours of daylight and 12 hours of night

## The Importance of the Parallels and Meridians

### The Parallels and Meridians

*Define the parallels and meridians*

Latitude refers to the angular distance North or South of the equator measured in degrees, minutes and seconds. The equator is given a value of 00. It is an imaginary line which divides the Earth into two hemispheres. The Northern hemisphere has a latitude of 90° N and the Southern hemisphere has a latitude of 90° S.

Therefore, Parallels of latitude are particular lines joining all points on the surface of the earth and making an angle of 90° N with the equatorial plane.

## How Latitudes and Longitudes are Determined

*Describe how latitudes and longitudes are determined*

### **THE IMPORTANT PARALLELS**

The important parallels include:

1. Equator 0°
2. Tropic of Cancer 23.5°N
3. Tropic of Capricorn 23.5°S
4. Arctic Circles 66.5°N
5. The Antarctic Circle 66.5°S

### **LONGITUDE**

Refers to the angular distance measured in degrees East and West of the Greenwich Meridian.

Prime Meridian is the line running through the poles and the Greenwich observatory near London. It is also known as Greenwich Meridian.

All lines of longitude are semi circles of equal length. Lines of longitude are also called meridians. There are 360° in a circle, 180° lie east of the Greenwich Meridian and the other 180° west of Greenwich.

The Greenwich lines have been chosen by convention (meaning that any other lines could have served the same purpose).

### **CALCULATION OF TIME**

The earth rotates on its own axis from West to East once every twenty four hours. This means 360° of longitude are covered in a period of 24 hours or 1° in four minutes. There are places on a given meridian that experience midday at the same time. Time recorded along the same meridian is known as Local Mean Time (LMT).

### Example 1

When the local time of Accra is 2.00pm what will be the local time of Bangui 15 degrees E.

Solution

$$15 \text{ degrees} - 0 \text{ degrees} = 15 \text{ degrees}$$

$$15 \times 4 \text{ minutes} = 60$$

$$60/60 = 1 \text{ hour}$$

$$\text{Accra } 2.00 \text{ pm} + 1.00 \text{ hour time difference} = 3.00 \text{ pm}$$

### Importance of a Great Circle

*Explain the importance of a great circle*

Any circle which divides the globe into hemispheres is a great circle. The equator is a great circle and Greenwich Meridian together with Meridian 180° make another great circle. The number of great circles is limitless.

The importance of great circles in geological applications of spherical projections is that they can represent planes. The center of a great circle is called its pole. If you know a great circle, you can find its pole, and if you know the pole, you can find the great circle. Thus it is possible to represent a plane by a single point. This fact is extensively used in advanced projection techniques. The perimeter of equatorial plane is called primitive circle.

## CHARACTERISTICS OF GREAT CIRCLES

1. All great circles divide the earth (sphere) into two hemispheres.
2. A great circle is the largest possible circle that can be drawn on the surface of the sphere.
3. The radius of great circles is the same as the radius of the earth.

## USES OF GREAT CIRCLES

Great circles are used to plot routes for ships crossing the vast oceans and aircraft flying great distance in space. Ships and aircraft travel by following great circles in order to save fuel and time because the shortest route between two places is along the circle of the great circle which passes through them.

## Importance of Parallels and Meridians

*Discuss the importance of parallels and meridians*

Parallels are another name for lines of latitude. You will see that these lines do not converge, or come together, anywhere on the globe. We call these parallels because they are always an equal distance apart. The first parallel is the equator. It is latitude 0. Latitude measures distance north and south from the Equator. Parallels are lines that circle the globe.

Meridians are another name for lines of longitude. These lines are drawn on maps and globes so that people can locate places. Meridians are lines that run from the North Pole to the South Pole. Meridians are not parallel. They converge or come together at the Poles. They number from the Prime Meridian (line 0) to 180W and from the Prime Meridian to 180E.

## Local time

*Calculate local time*

### Example 2

What is the local time at Morogoro-Tanzania when it is noon at Kigali-Rwanda?

Procedure

1. Note the longitudinal position between the two points Kigali 30°E and Morogoro 45°E
2. Find the difference in degrees of longitude between Kigali and Morogoro 45 degrees - 30 degrees = 15 degrees
3. Multiply the difference by 4 minutes  $15^\circ \times 4 \text{ minutes} = 60 \text{ minutes}$ ;  $60 \div 60 = 1 \text{ hour}$
4. The time difference is to be added (+) in case of places to the East of a point. In case of place to the West, the time difference is subtracted (-). Since Morogoro is to the East of Kigali,

Morogoro time will be ahead of that of Kigali's by 1 hour, therefore time for Morogoro will be: 12.00 noon + 1 hour = 1.00 pm.

## Time and Time Zone

*Define time and time zone*

Time means duration or suitable moment for some purpose.

Time zone refers to a zone where standard time is accepted throughout a longitudinal zone 150 in width.

## Essence of Time and Time Zone

*Explain the essence of time and time zone*

The importance of time zones is to avoid the problems in telling time if every place had its own time set according to the local mean time.

The timetable of various human activities such as television and radio programs would be confusing if they had to show different times.

As the time varies from place to place, different stretches of land agreed to adopt the time from certain meridian, that time is known as standard time.

East African countries agreed to adopt standard time taken from meridian of 45°E. When a whole stretch of land keeps to the same standard time that stretch of land forms a time zone.

## Variation of Standard Time in a Single Country

*Explain variation of standard time in a single country*

Large countries like USA, China, etc have several standard time zones with each time zone covering about 15 degrees of longitude. There are 24 time zones in the world. The starting point for dividing the world into 24 time zones is the Greenwich Meridian. The standard time for Greenwich is known as the Greenwich Meridian time (GMT).

## International Date Line

*Define International Date Line*



The International Date Line is the line where date is changed or calendar day begins. This line follows approximately the 180° meridian.

## Location of International Date Line

### *Locate International Date Line*

When the time is 6.00pm on Monday 25th December, at Greenwich, the time at 180° E longitude will be 12 hours ahead of Greenwich Mean Time. The time at 180° E will be 6.00am on Tuesday 26th December. Therefore if one travels eastwards and crosses the date line, one will gain a day whereas one who travels westwards across the line will lose a day.

# MAJOR FEATURES OF THE EARTH'S SURFACE

## Continents

### Meaning of a Continent

*Explain the meaning of a continent*

The land surface occupies 29% of the surface of the globe, and the remaining 71% is covered by water. The land surface forms seven continents. A continent is a major landmass rising from the ocean floor. It includes islands adjacent to the continent. There are seven continents namely, Africa, Asia, South America, North America, Europe, Australia and Antarctica. These continents are surrounded by the following oceans: The Indian Ocean, the Atlantic Ocean, the Pacific Ocean, the Arctic Ocean and the Southern ocean.

There is more land surface in the northern hemisphere than in the southern hemisphere but there is more water surface in the southern hemisphere than in the northern hemisphere. The continents are broader in the northern hemisphere. The seven continents that make up the globe are explained below:

1. **Australia:** Australia is the smallest continent and it is about a quarter of the size of Africa. Its size is about 8.5 million square kilometres. Australia is approximately 10°S and 40°S and between 115°E and 150°E. The islands of New Zealand to the south east of Australia are part of this continent. The continent is bordered to the west and north by the Indian Ocean, to the east by the Pacific Ocean, and to the south by the Southern Ocean.
2. **Europe:** Europe is the sixth continent in size and it is about two-fifth the size of Africa. The size of Europe is 9.8 million square kilometres. Most of Europe lies between 40°N and the 1 Arctic circle, and between 10°W and 60°E. It lies to the west of Asia, separated by the Ural Mountains. Europe is bordered to the north by the Arctic Ocean, to the west by the Atlantic Ocean, and to the south by the Mediterranean Sea.
3. **Antarctica:** Antarctica is the fifth continent in size and it is about one-third the size of Africa. Its area is about 11.4 million square kilometres. This is the southernmost continent,

forming a circle at the South Pole and extends south of  $66\frac{1}{2}^{\circ}\text{S}$ . It is surrounded by the southern ocean. The continent is mostly uninhabited.

4. **North America:** North America is the fourth continent in size and it is slightly more than half the size of Africa. Its size is about 17.9 million square kilometres. It extends from  $10^{\circ}\text{N}$  to  $65^{\circ}\text{N}$  and from  $60^{\circ}\text{W}$  to  $160^{\circ}\text{W}$ . It is bordered to the west by the Pacific Ocean, to the East by the Atlantic Ocean, and the North by the Arctic Ocean.

5. **South America:** South America is the third largest continent and it is about two-thirds the size of Africa. Its size is about 24.3 million square kilometres. It lies between  $10^{\circ}\text{N}$  and  $50^{\circ}\text{S}$  and between  $35^{\circ}\text{W}$  and  $80^{\circ}\text{W}$ . This continent is bordered to the east by the Atlantic Ocean, to the West by the Pacific Ocean, and it is joined to North America by the Isthmus of Panama.

6. **Africa:** Africa is the second largest continent with an area of about 3.6 square kilometres. Africa extends from  $37^{\circ}\text{N}$  to  $35^{\circ}\text{S}$  and from  $50^{\circ}\text{W}$  to  $50^{\circ}\text{E}$  and it is crossed by Tropics of Cancer and Capricorn. Thus the greater part, about three quarters of the whole area lies in the tropics. Africa is bordered to the north by the Mediterranean Sea, to the west by the Atlantic Ocean, and to the East by the Indian Ocean.

7. **Asia:** Asia is the largest of all continents. It covers more than one third of the land surface of the earth. It is approximately one and a half times the size of Africa. Its total area is about 45.6 million square kilometres. Asia stretches from  $0^{\circ}$  to  $67^{\circ}\text{N}$  and from  $30^{\circ}\text{E}$  to about  $18^{\circ}\text{E}$ . The Ural Mountains form the boundary between Asia and Europe. This continent is attached to Africa by the narrow Isthmus of Suez which has been dug to form the Suez Canal. The continent is bordered to the North by the Arctic Ocean, to the East by the Pacific Ocean, and to the South by the Indian Ocean.

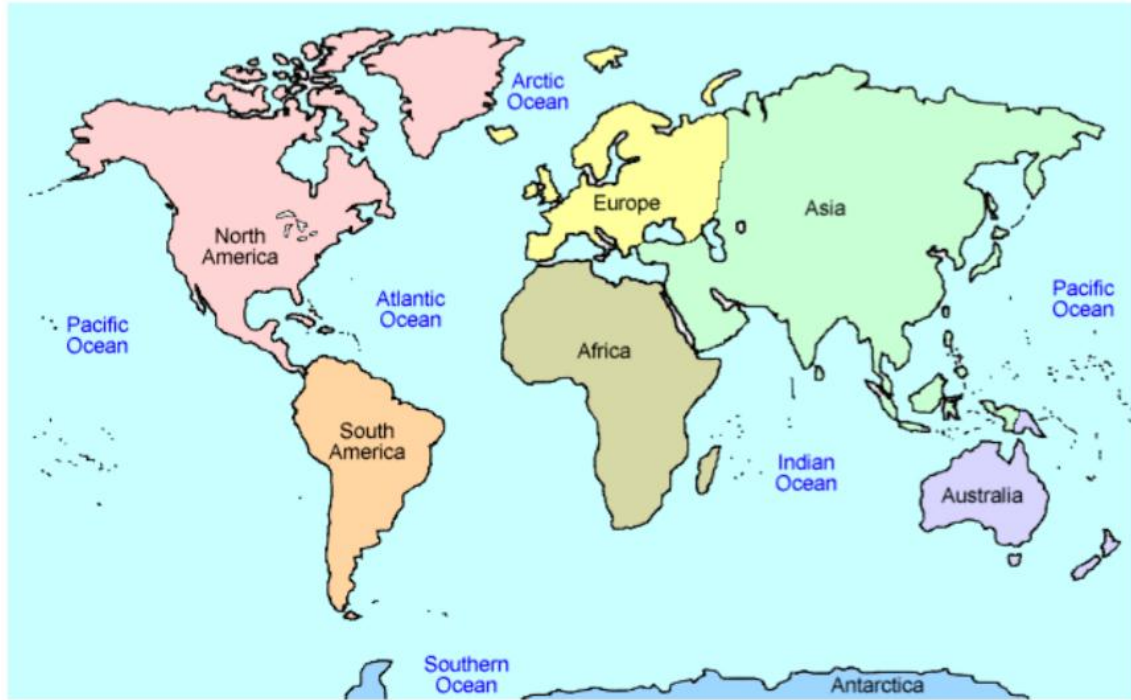

The following table summarizes the location and area of all seven continents discussed above:

| Continent     | Geographical location                       | Area (Million Km <sup>2</sup> ) |
|---------------|---|---------------------------------|
| Asia          | 0° - 67° N; 30° - 180° E                    | 45.6                            |
| Africa        | 37° N - 55° S; 15° W - 50° E                | 30.6                            |
| South America | 10° N - 50° S; 35° W - 80° W                | 24.3                            |
| North America | 10° N - 65° N; 60° W - 160° W               | 17.9                            |
| Antarctica    | Between the South Pole and 66½ °S           | 11.4                            |
| Europe        | 40° N and the Arctic Circle ; 10° W - 60° E | 9.8                             |
| Australia     | 10° S - 40° S; 115° E - 150° E              | 8.5                             |

### Major Features of the Continent

*Identify the major features of the continent*

The surface of the continents is not smooth. It has mountains, hills, rivers and valleys, plateaus, and plains. Mountains are landforms which have high relief generally over 300 metres above the surrounding area. Hills are landforms that have moderate relief generally between 150 and 300 metres above the surrounding area. Plateaus are extensive highland areas with more or less uniform summit level, bounded by one or more slopes falling steeply away, sometimes rising on one or more sides by steep slopes to mountain ridges. Plains are continuous stretches of comparatively flat land not much above sea level, sometimes gently rolling or undulating.

## **Mountains**

There are four types of mountains. These are the Fold Mountains, Block Mountains, Residual Mountains, and Volcanic Mountains. These mountains are all named according to the way they were formed.

- ***Fold Mountains:*** Fold Mountains are formed by wrinkling or (folding) of the Earth's crust. Fold Mountains usually form parallel ranges which extend for hundreds of miles across a continent. Thus, Fold Mountains are the most extensive ranges in the world. For example, the Rocky Mountains in North America vary in width from 640 to 1,600 kilometres and are about 5,000 kilometres in length. These types of mountains have some of the highest peaks in the world. Mount Everest in the Himalayas is 8,848 metres above sea level and the Aconcagua in the Andes is 7,003 metres above sea level. Examples of Fold Mountains include the Himalayas in Asia; the Rockies in North America; the Andes in South America; the Alps in Europe; the Atlas in North Africa; the Cape ranges in South Africa; the Appalachians in the USA; and the Great Dividing Ranges in Australia.

- ***Block Mountains:*** Block Mountains are formed when a movement in the earth's crust forces the rocks to break instead of folding. As a result enormous cracks or faults are formed. When two sets of faults run parallel to each other and the ground between is forced to rise up, a block (fault) mountain is formed. Usually Block Mountains do not extend over wide areas as Fold Mountains do. Examples of Block Mountains are the Usambara, Uluguru and Ruwenzori Mountains in Africa; the Vosges and Black Forest Mountains in Europe; and Mount Sinai in Asia.

- **Residual Mountains:**Residual mountains are formed when an area of highland remains standing above the general level of land after the rivers and other natural agents have lowered the surface of the surrounding area. Sometimes such highlands are called mountains of denudation. These mountains may in some cases appear as isolated hills but in other cases they appear as long ridges, generally steep on one side (the scarp slope) and gentle on the other side (dip slope). Examples of residual mountains are the Ahaggar Mountains of central Sahara; the Sekenke hills of Singida in Tanzania; the Admawa mountains of eastern Nigeria; the Highlands of Scotland; the Sierras of central Spain; and the Mesas and Buttes of the western plateau of the United States.

- **Volcanic Mountains:**Volcanic mountains are formed from the piling up and cooling of hot molten lava and ashes that are thrown out from the earth's interior after a volcanic eruption. Some of the volcanic mountains existing today were built up by a single eruption, but others were built by several eruptions. Volcanic eruptions are still taking place in some parts of the earth. Among the existing volcanic mountains, some still experience periodic eruptions, for example, the Vesuvius in Italy; the Krakatoa in Indonesia; the Mufimbiro in Uganda; and the Oldoinyo-Lengai in Tanzania. The Volcanic Mountains that still experience periodic eruptions are called active volcanic mountains. The Volcanic Mountains which erupted once in historical times and are no longer active are said to be dormant. In this group are included the Kilimanjaro and Meru mountains in Tanzania. Those volcanic mountains which have never experienced eruption and have shown no signs of erupting again are said to be extinct (dead). Included in this group are mountains Kenya, Elgon, Ngorongoro and Rungwe in East Africa; and Demavend in Iran. Volcanic mountains are usually conical in shape and mostly contain craters or depressions at their summits, for example, mountains Fujiyama and Kilimanjaro. Sometimes the craters are filled with water to form crater lakes.

## **Plateaus**

In geology and earth science, a plateau (plural: plateaus or plateaux), also called a high plain or tableland, is an area of highland, usually consisting of relatively flat terrain that is raised significantly above the surrounding area, often with one or more sides with steep slopes.

The largest and highest plateau in the world is the Tibetan Plateau, called the "roof of the world". The Tibetan plateau covers approximately 2,500,000 km<sup>2</sup> at about 5,000 m above sea level.

The second-highest plateau is Deosai National Park (also known as Deosai Plains) at an average elevation of 4,114 m and is located in the Skardu District of Gilgit-Baltistan, in northern Pakistan.

The third-largest plateau is the Antarctic Plateau, which covers most of central Antarctica, where there are no known mountains, but rather 3,000 m or more of ice.

Other plateaus in the world include the Colorado Plateau (North America); the Great Central Plateau, Ahaggar Plateau and Fouta Djallon Plateau (Africa); Brazilian Plateau (South America), Mexican Plateau and Laurentian Plateau (North America); Arabian Plateau, Deccan Plateau and Tibet Plateau (Asia).



## Plains

A plain is a broad area of relatively flat land. Plains are one of the major landforms, or types of land, on Earth. They cover more than one-third of the world's land area. Plains exist on every



continent except Antarctica. Plains occur as lowlands and at the bottoms of valleys but also on plateaus or uplands at high elevations.

Plains in many areas are important for agriculture because where the soils were deposited as sediments they may be deep and fertile, and the flatness facilitates mechanization of crop production; or because they support grasslands which provide good pasture for livestock.

Plains vary widely in size. The smallest occupy only a few hectares, whereas the largest cover hundreds of thousands of square kilometres. For example, the Great Plains of North America extends from Pyrenees Range on the French–Spanish border across northern Europe and Asia, almost halfway around the world.





*The Yellow River winds through the plains of Sichuan, China. Many rivers are surrounded by plains, or broad areas of flat land.*

## Water Bodies

### Meaning of a Water Body

*Define a water body*

A water body is any significant accumulation of water, generally on a planet's surface. The term most often refers to oceans, seas, and lakes, but it includes smaller pools of water such as ponds, wetlands, or more rarely, puddles. A body of water does not have to be still or contained. Rivers, streams, canals, and other geographical features where water moves from one place to another are also considered water bodies.

### Oceans and Other Water Bodies

*Identify the oceans and other water bodies*

An ocean is defined as a body of saline water covering much of the earth. The largest ocean is the Pacific. Its area is about 165.3 million square kilometres. The second largest ocean is the Atlantic, which covers about 82.2 million square kilometres. The Indian Ocean, covering about 73.4 square kilometres is the third largest, followed by the Arctic Ocean, covering about 14.0 million square kilometres.



## Composition of ocean water

Ocean water contains a number of dissolved mineral salts. These mineral salts include sodium chloride (common salt) which makes up 78% of all salt in the ocean water; and compounds of magnesium, potassium and calcium. Most of the minerals in the ocean are a result of constant accumulation since the formation of the oceans. However, a small amount of the minerals come from the land, having been dissolved by water and brought into the ocean by rivers. But the mineral salts in rivers are only in very small quantities.

The saltiness of the ocean water is not the same everywhere. Saltiness of the ocean water depends mainly on temperature which affects the amount of salt that can dissolve in the water, the amount of fresh water brought into the ocean by rivers and rainfall, and the amount of evaporation taking place from the surface.

## **Water temperature**

Water is heated by the sun's rays much more slowly than land is. Water also loses heat to the air around it more slowly than the land does. This causes the temperature of the sea water to vary only slightly from season to season. In general, the temperature of the ocean water decreases from the equator, where the surface temperature is 25°C to the polar regions where the water is very cold (-2.2°C). But the decrease in temperature poleward is not uniform because of the occurrence of warm and cold ocean currents. On the other hand, water temperature decreases with depth in the tropics up to the depth where the temperature is 1.1°C.

## **Water movements**

Ocean water is constantly in motion. There are two types of movement. One is horizontal movement, which is in the form of ocean currents and tides, and the other is vertical, which is the rising of subsurface water and the sinking of the surface water. The movements of ocean water are a result of density variations in the water which is particularly important in vertical movements and winds which are particularly important in horizontal movements.

An ocean current is the permanent or seasonal movement of surface water in the ocean. There are warm and cold currents, the ocean currents are set in motion by a combination of prevailing winds, differences in density and temperature of the ocean waters, the rotation of the earth, and the shape of landmass.

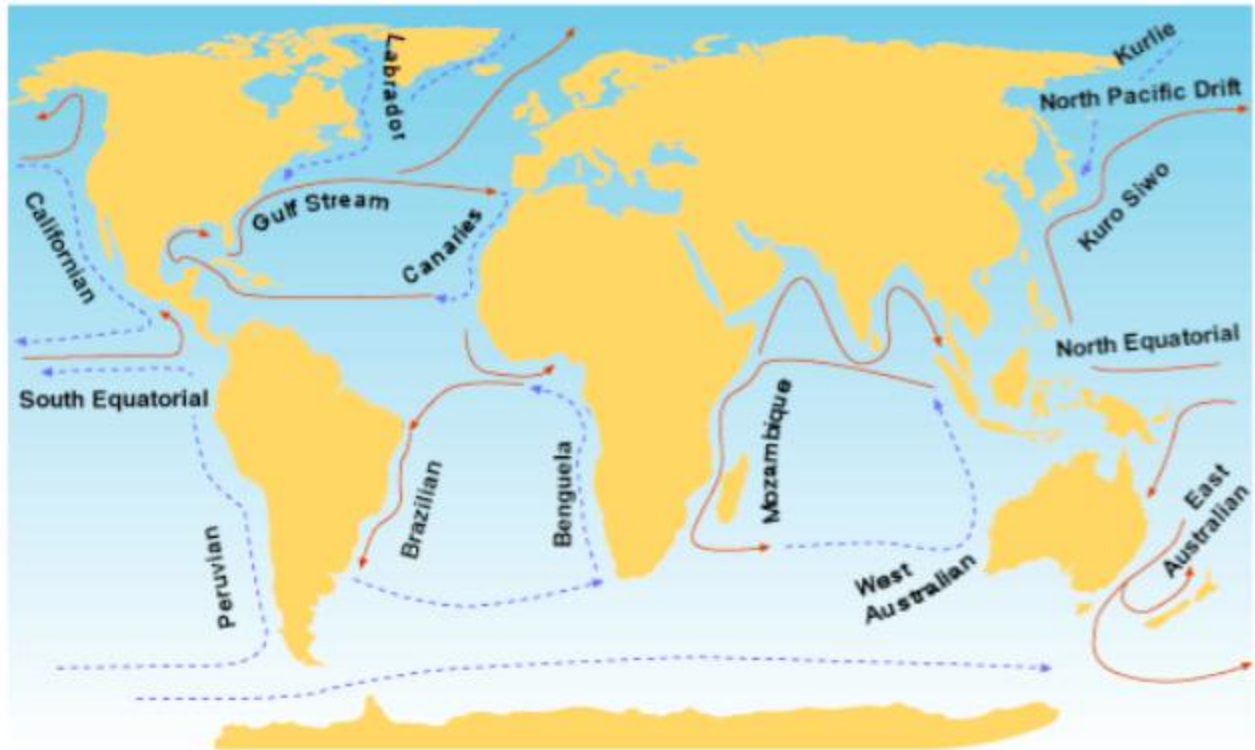

**KEY**

- - -> Cold Current
- > Warm Current

*Major ocean currents*

Tides are the rising and the falling in the level of water in the oceans, seas and lakes. They occur twice a day (in 24 hours). The level to which tides rise and fall varies from day to day. On the days when it rises to its highest level, it also falls to its lowest level. The rising and falling is caused by the pull of gravity of the moon and the sun.

Waves are to and from movements of the surface water. When water is thrown into waves, its surface gets a shape of ups and downs. The highest part of the wave is called the crest and the lowest the trough. The distance from one crest to the next, or from trough to trough is called the wavelength. Waves travel in some definite direction, and give the impression that they move forward, but in reality only the shape moves forward while the water moves up and down. For example, a cork thrown into the water does not travel with the waves, it moves up and down and to and fro, but not forwards. A wave is driven on the shore by wind, and its height and force are determined by the strength of the wind and the distance of open water over which it has blown.

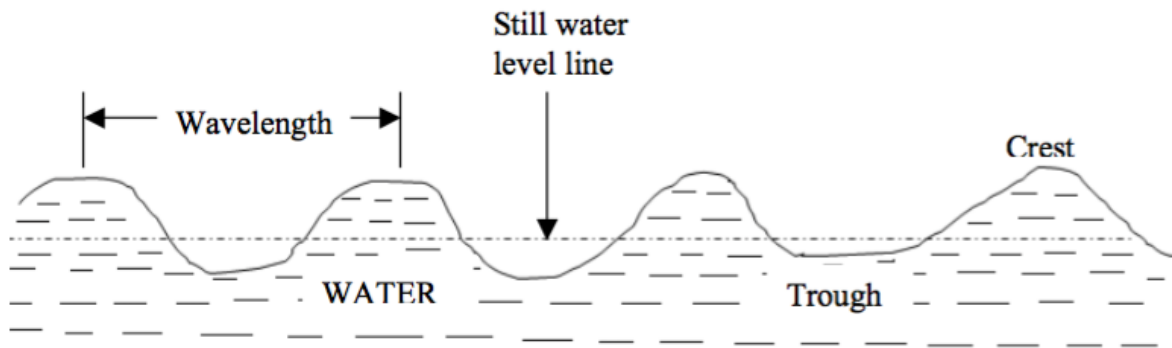

*Water waves*

## **Lakes**

A lake is a natural or man-made body of water that is surrounded by land. Lakes lie on land and are not part of the ocean, and therefore are distinct from lagoons, and are also larger and deeper than ponds, though there are no official or scientific definitions. Most lakes are fed and drained by rivers and streams.

Some lakes are artificial (man-made lakes) and are constructed for industrial or agricultural use, for hydro-electric power generation or domestic water supply, or for aesthetic or recreational purposes. Examples of man-made lakes include Lake Nasser (in Egypt), Lake Kariba (Zambia), and Lake Volta (Ghana).

The majority of lakes on Earth are fresh water, and most lie in the Northern Hemisphere at higher latitudes. Most lakes have at least one natural outflow in the form of a river or stream, which maintains a lake's average level by allowing the drainage of excess water. However, some lakes do not have a natural outflow and lose water solely by evaporation or underground seepage or both.

Lakes are not evenly distributed on the earth's surface; most are located in high latitudes and mountainous regions. Although lakes are usually thought to be freshwater bodies, many lakes, especially in arid regions, become quite salty because a high rate of evaporation concentrates inflowing salts. The Caspian Sea, Dead Sea, and Great Salt Lake are among the greatest of the world's salty lakes. The Great Lakes of the United States and Canada is the world's largest system of freshwater lakes. Lake Superior alone is the world's largest freshwater lake with an

area of 82,414 sq km. The Caspian Sea is the largest lake in the world, with an area of 372,960 sq km. Lake Titicaca in the Andes Mountains of South America is the world's highest lake at 3,800 m above sea level; while the Dead Sea is the lowest at 425 m below sea level.

## Rivers

A river is natural water flowing in a definite channel towards an ocean, sea, lake, desert basin, marsh or another river. In some cases, a river flows into the ground and become dry at the end of its course without reaching another body of water. Small rivers can be referred to using names such as stream, creek, brook, rivulet, and rill.

Rivers are part of the hydrological cycle. Water generally collects in a river from precipitation through a drainage basin from surface runoff and other sources such as groundwater, springs, and the release of stored water in natural ice and snowpacks (e.g. from glaciers).

Examples of rivers in Africa include the Nile, Congo, Niger, Zambezi and Orange. In Tanzania we have rivers like Rufiji, Ruvuma, Ruaha, Pangani, Wami and Malagalasi.

## Features of the Ocean Floor

*Describe the features of the ocean floor*

The floor of the ocean is irregular. The major relief features of the ocean floor are explained below:

1. **Continental shelf:** This is a gentle-slope margin of a continent that forms the shallow areas of oceans. These shallow areas extend from the coast to a depth of about 200 metres towards the ocean, and usually end suddenly.
2. **Continental slope:** The continental slope is found at the point where the continental shelf forms a steep slope with the lower slope of the ocean floor towards the sea.
3. **Ridge:** A ridge is the raised part of the ocean floor. Some of these ridges appear above the surface of the oceans as oceanic islands.
4. **Ocean deep or trench:** An ocean deep is a long, narrow depression (or trough) found on the ocean floor.
5. **Deep sea plain (ocean plain):** An ocean plain is the most extensive, flat area of the ocean floor. It is a monotonous and undulating area. A large part of the plain is covered by mud.



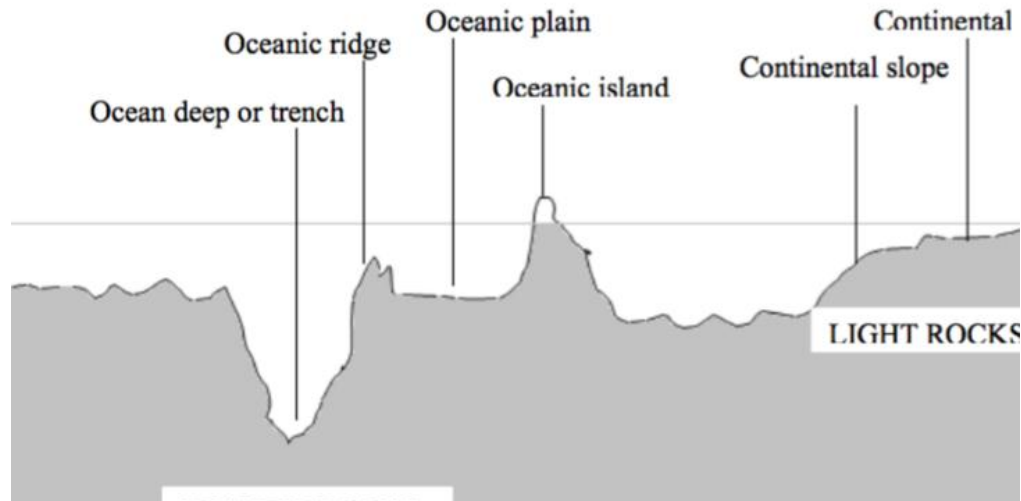

A generalized section across an ocean floor

## The Map Showing the Distribution of Continents and Water Bodies

Draw the map to show the distribution of continents and water bodies

The Map showing distribution of water bodies.



# WEATHER

## Concept of Weather

### Meaning of Weather

#### *Define weather*

Weather is defined as conditions of the atmosphere which occur at a place at specific time periods, that is, from hour to hour or day to day. It changes from time to time and from place to place. For example, it may be raining in the morning and sunny in the afternoon.

Weather may also be defined as the day-to-day state of the atmosphere, and its short-term variation in minutes to several weeks.

How do you feel when seated in a classroom on a cloudy day? You probably feel cold. Don't you? Now, suppose you move outside the classroom on a sunny day and stay there for several minutes. Your body will obviously feel hot and may even start to sweat. What does this experience tell you about the weather?

The weather is all around us, all the time. It is an important part of our lives and one that we cannot control. Instead the weather often controls how and where we live, what we do, what we wear and what we eat.

The scientific study of weather is called meteorology and a person who studies weather is called meteorologist.

### Importance of Weather

#### *Describe the importance of weather*

Weather is an important part of the natural environment. It directly or indirectly affects many of our activities. The following are some of the reasons why weather is important to mankind and the surrounding environment:

1. Weather is one of the fundamental processes that shape the Earth. The process of weathering breaks down the rocks and soils into smaller fragments and then into their constituent



substances. In this way, weather plays a major role in erosion of the surface soil, hence shaping the earth.

2. The weather of any given region is important because it has a considerable impact on the water, sunlight and temperature of an ecosystem. Variation in long-term weather patterns and tendencies can result in certain regions getting more or less water or sunlight than other areas. These factors play an important role by influencing the type of plants and animals that can survive in the area.

3. Certain weather patterns can also cause dangerous storms and natural disasters. We tend to be acutely aware of the weather when we are faced with exceptional or dangerous phenomena that could endanger our property, safety or even lives. Such phenomena are, for example, strong winds, hail, heavy rainfall, sleet, ice and frost.

4. Studying weather characteristics of a given place over along period of time (usually 30 to 40 years) enables the climatic conditions of that place to be established. Therefore, weather can be used as a basis for determining the climate of a given place.

5. The knowledge of weather (and hence climate) enables people to carry out their economic activities depending on the weather and climatic conditions of their localities. For example, people living in cold areas which receive high rainfall can engage in dairy farming and the growing crops such as tea, coffee, banana, etc.

## The Relationship between Weather and Human Occupations

*Show the relationship between weather and humans occupations*

There is a direct relationship between the weather condition and nature of human activity. Due to the fact that deserts experience very hot weather, it will be surprising to see tea or banana tree growing there. This way we can see a clear connection between the two. E.g, during rainfall, construction companies experience lows in business and meanwhile floods hinder transport on rivers.

## Elements of Weather

## Elements of Weather

### *Name elements of weather*

Weather elements refer to a combination of natural phenomena that make up the weather. There are several elements that make the weather and climate of a place. The weather elements are temperature, pressure, precipitation, wind, humidity, clouds and sunshine.

The study of these elements can provide the basis for forecasting weather and defining the climate. Now, let us study each element in more details:

## Temperature

The temperature is how hot or cold the atmosphere is, usually measured by a thermometer and expressed in degrees on a Centigrade or Fahrenheit scale. There are several types of thermometers. The maximum thermometer shows the highest temperature reached during a given period, for example a day; while the minimum thermometer shows the lowest temperature recorded (the figure below shows maximum and minimum thermometers).

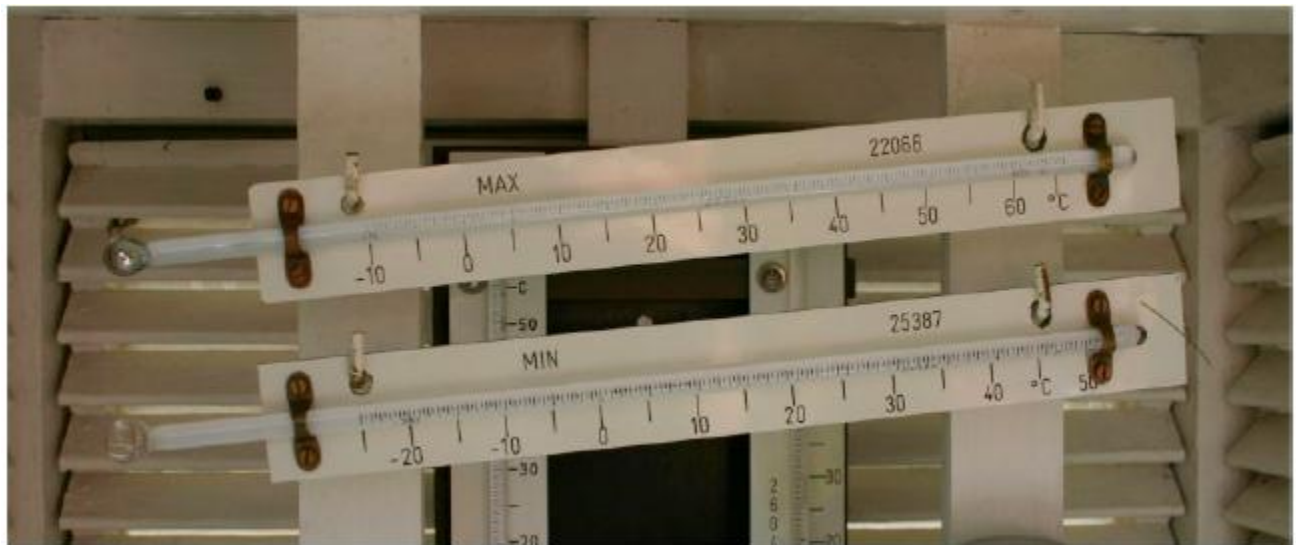

### *Maximum and minimum thermometers*

The maximum thermometer is made of glass and contains mercury in the bulb. The minimum thermometer is also made of glass but contains alcohol instead of mercury. The thermometer is marked in degrees of Centigrade or Fahrenheit. When the temperature rises, the mercury expands and extends along a glass tube. Changes in temperature are shown by the length of mercury. For

example, if the lowest temperature reads  $12.5^{\circ}\text{C}$  and the maximum temperature reads  $24.0^{\circ}\text{C}$ , then the changes in temperature is calculated as  $24.0 - 12.5 = 11.5^{\circ}\text{C}$ .

The Six's thermometer can also be used for measuring maximum and minimum temperature. The thermometer consists of a U-shaped glass tube. The metal index nearest to the bulb indicates the minimum temperature and the other metal index records the maximum temperature.

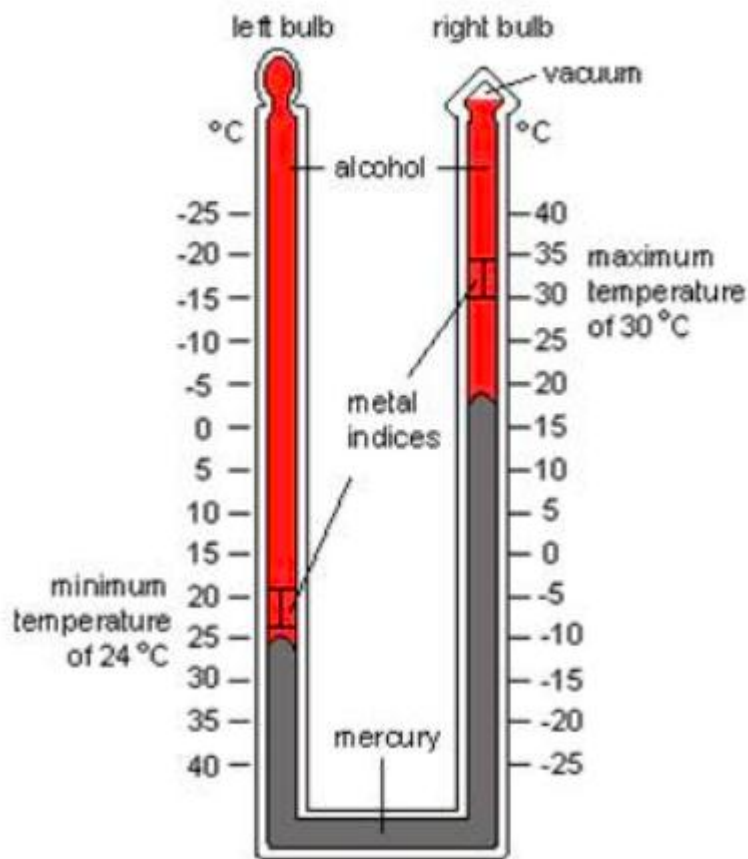

*Six's Thermometer. Can you read the max temperature and min temperature?*

Temperature is a very important factor in determining weather. It influences or controls other elements of weather, such as precipitation, humidity, clouds and sunshine. The factors affecting (modifying) temperature include latitude, altitude, distance to the ocean and/or sea, orientation of mountain ranges toward prevailing winds (aspect) and ocean currents.

Reading and recording temperature

The maximum and minimum temperatures which are recorded for the day are used to calculate:

- a. daily range of temperature, which is the difference between the maximum and minimum temperatures; and
- b. the daily mean, which is the average of maximum and minimum temperatures.

$$\text{Maximum} + \text{Minimum}/2 = \text{Daily mean}$$

The monthly range of temperature is the difference between the highest daily mean temperature and the lowest daily mean temperature. To get the lowest mean temperature for a particular month, add up the mean daily temperatures and divide by the number of days in that month. For example, the mean monthly temperature for January is given by:

$M_1 + M_2 + M_3 + \dots + M_n/31$  where  $M_1, M_2, M_3, \dots, M_n$  are the mean daily temperatures for days 1, 2, 3, ..., n; and 31 is the number of days in January. The same formula can be applied to obtain the maximum daily mean temperature for a particular month.

The annual range of temperature in a particular year is the difference between the highest mean monthly temperature and the lowest mean monthly temperature.

When reading and recording of data is done over a period of time, the obtained data can be shown on maps. These maps are called temperature maps. When comparing the temperature in different parts of the world, it is usual to make use of temperature maps. Different places with the same temperature conditions can be joined on the map by lines called isotherms.

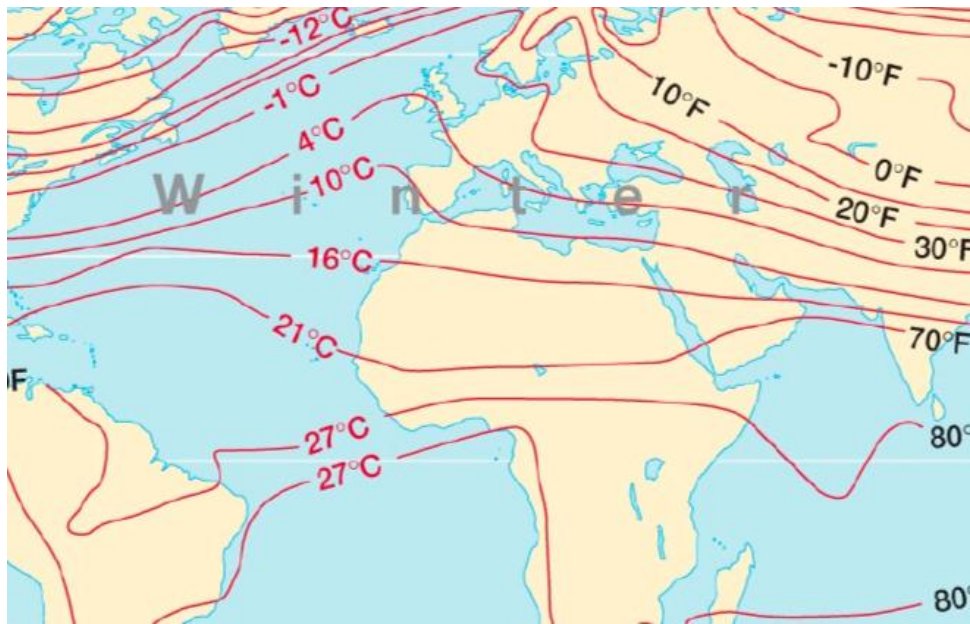

### *Isotherms*

#### Relationship between temperature and altitude

Temperature decreases at the rate of  $0.6^{\circ}\text{C}$  for every 100 metres increase in altitude. Therefore, temperatures in highland areas are lower than temperatures in lowlands.

Apart from isotherms, another way of presenting the temperature data is using a graph. In this case, temperature figures are plotted on the graph and points are joined by a smooth line.

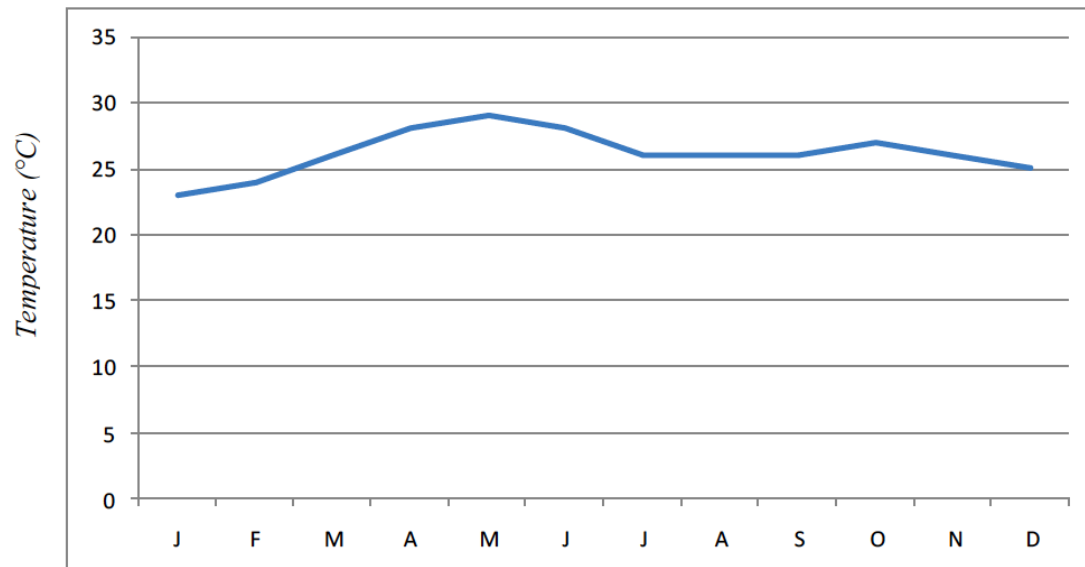

*Average monthly temperature for Station X*

## Precipitation

This refers to the deposition of moisture on the earth's surface from the atmosphere. This moisture includes rain, snow, ice, hail, mist and sleet.

Demonstrating the formation of rain

Boil some water in a pot. Just as the water starts boiling, hold a container filled with cold water over the pot. As the steam comes in contact with the container, it condenses to form droplets which will then fall down. This explains how rain is formed.

The sun's heat causes water to evaporate from the surface of the oceans, lakes, rivers other water bodies, and land. This vapour rises into the atmosphere where it condenses to form clouds. Because the air is cooler at higher altitudes, the vapour is cooled to form small droplets that join together to form larger drops which are then too heavy to remain in the air, so they fall as rain. The diagram below shows the water cycle, also called the hydrologic cycle.

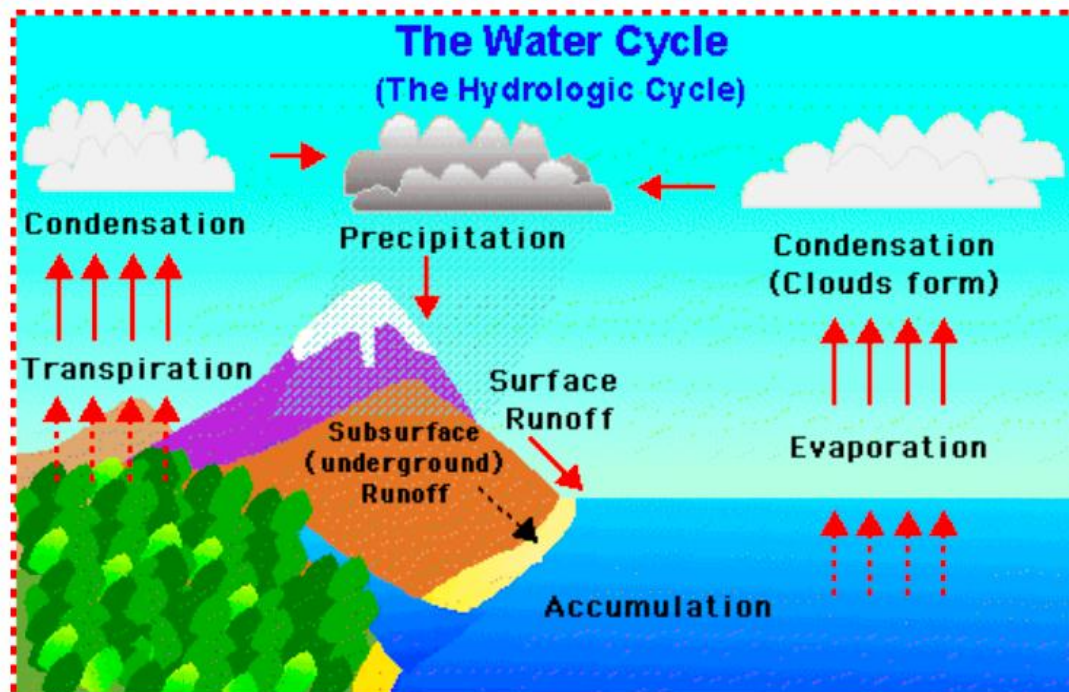

*The hydrologic cycle*

Types of rain

There are three types of rain as explained below:

## Convection rain

This is a rain formed through the rising of the moist air currents, which condenses at higher altitudes to form clouds that result to rainfall.

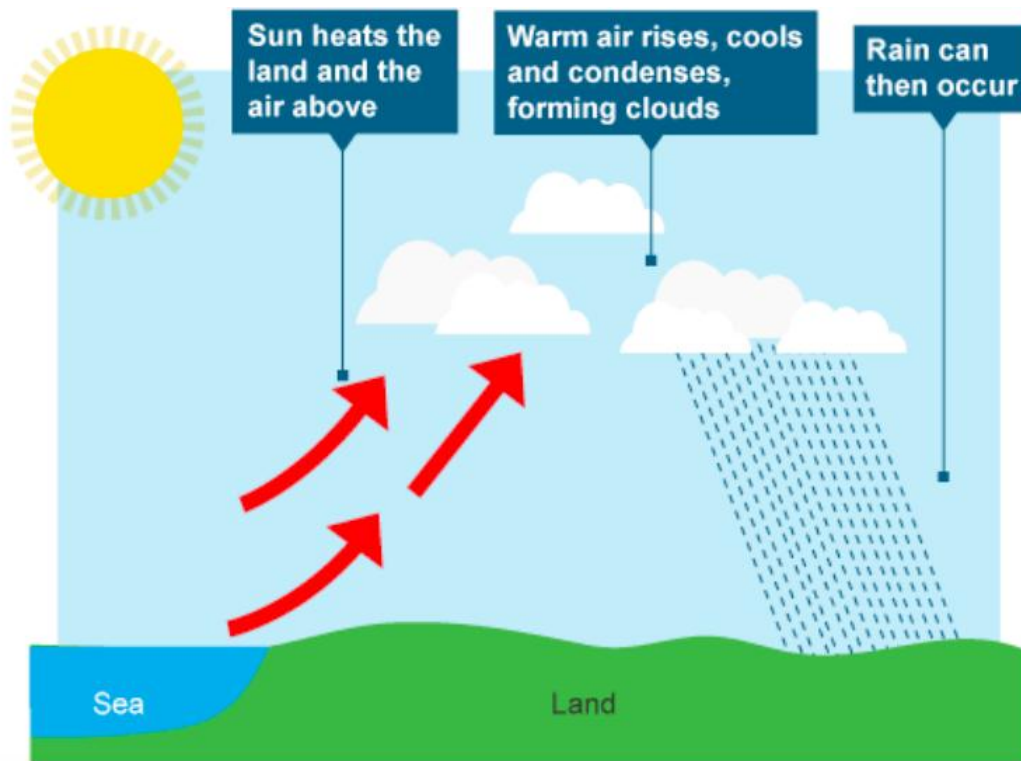

## *Convection rain*

### Orographic rain or relief rain

Sometimes moist winds are forced by a high mountain to rise and the moisture in it condenses to form rain. Rain formed in this way is called orographic rain. The side of the mountain facing away from the direction of wind gets little or no rain. This phenomenon is called the rain shadow effect.



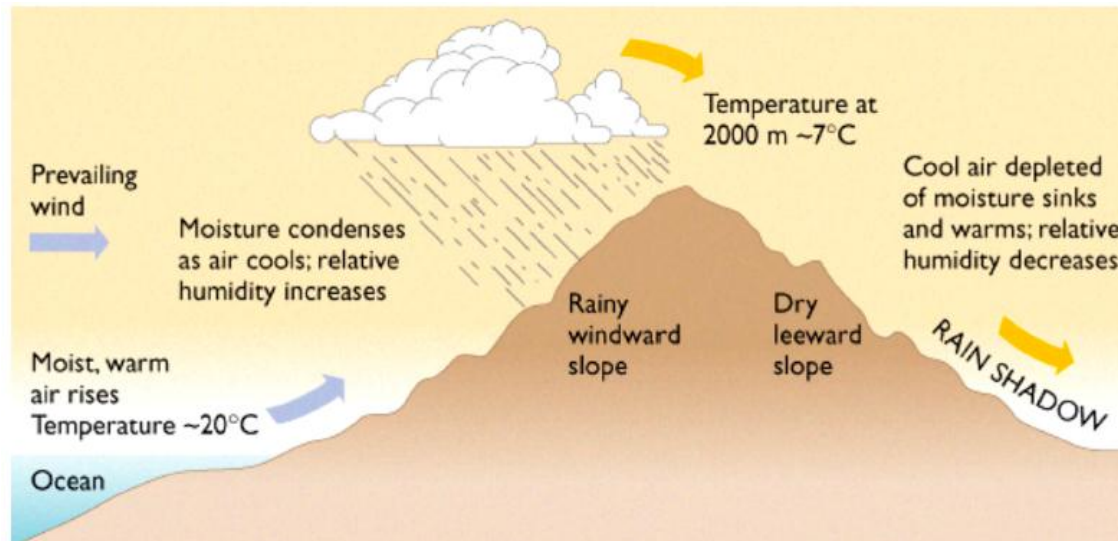

### *Orographic rain*

An example of the rain shadow effect in Tanzania is found on the western side of Mount Kilimanjaro. Winds blow from the Indian Ocean in the east and are forced by this Convection rain mountain to rise up and drop moisture on the eastern and south western slopes. When these winds blow over to the western side of the mountain, they are already relatively dry. As a result, they bring very little rain to the Masai steppe. Other examples are the Rocky Mountains which affect the rain-bearing winds from the Pacific; and the Andes in Chile which affect the rain bearing winds from the Pacific on the Patagonia plateau.

### *Cyclonic rain*

Cyclonic rain occurs when large masses of air with different characteristics of temperature and moisture meet. As the warmer and moist air is forced up over the cooler and dry air, it expands, cools and water vapour condenses to form clouds and rain.



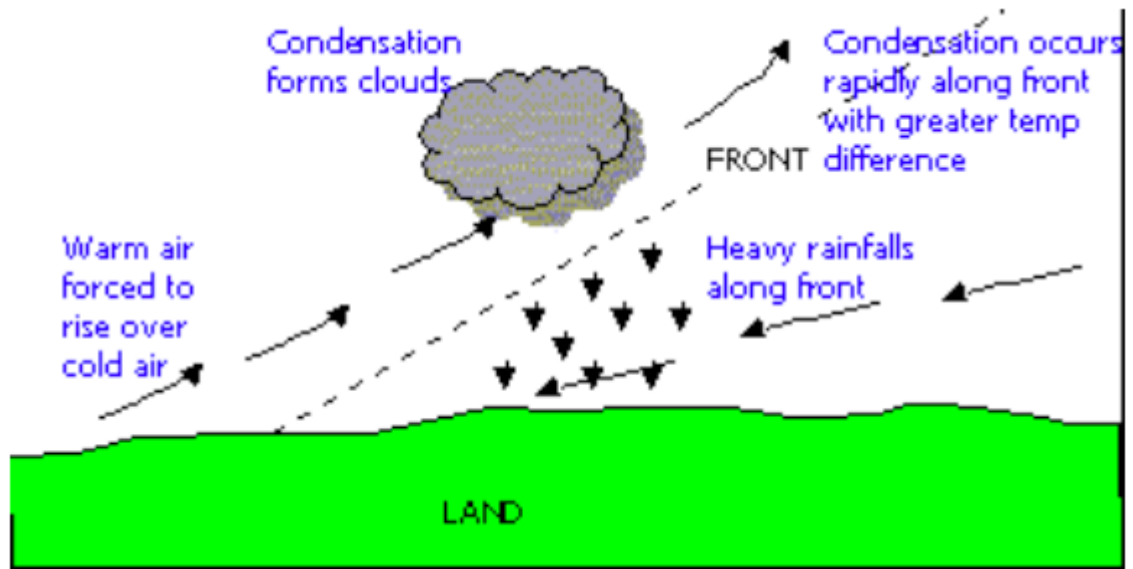

### *Cyclonic rain*

On the other hand, tropical cyclones are formed over oceans in the tropics between latitude  $8^{\circ}\text{N}$  and  $8^{\circ}\text{S}$ . They usually bring very heavy rainfall and are associated with thunderstorms and very fast moving winds which often cause destructions along coastal settlements. In the Caribbean and USA, tropical cyclones are called hurricanes. In Africa they are known as cyclones, while in China and Japan they are called typhoons but in North Australia they are known as Willy-Willies.

Rainfall is measured by an instrument called rain gauge. Normally, the reading is done once every 24 hours. If need be, comments on the nature, time and duration of rainfall should be added to the record.

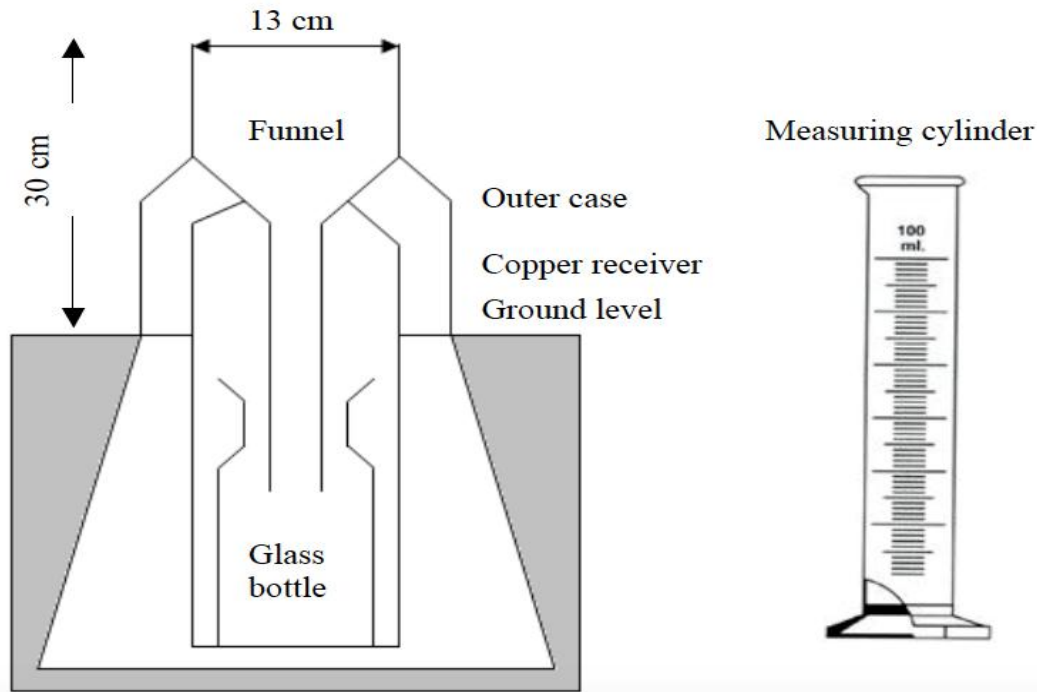

### *THE RAIN GAUGE*

Rainfall figures entered in the record book for the month or several months can be represented in the form of graphs known as histograms (see the histogram below). Mean monthly rainfall records are usually obtained by adding up rainfall of a particular month (say January) for a number of years (say 30 years) and dividing this by the same number of years.

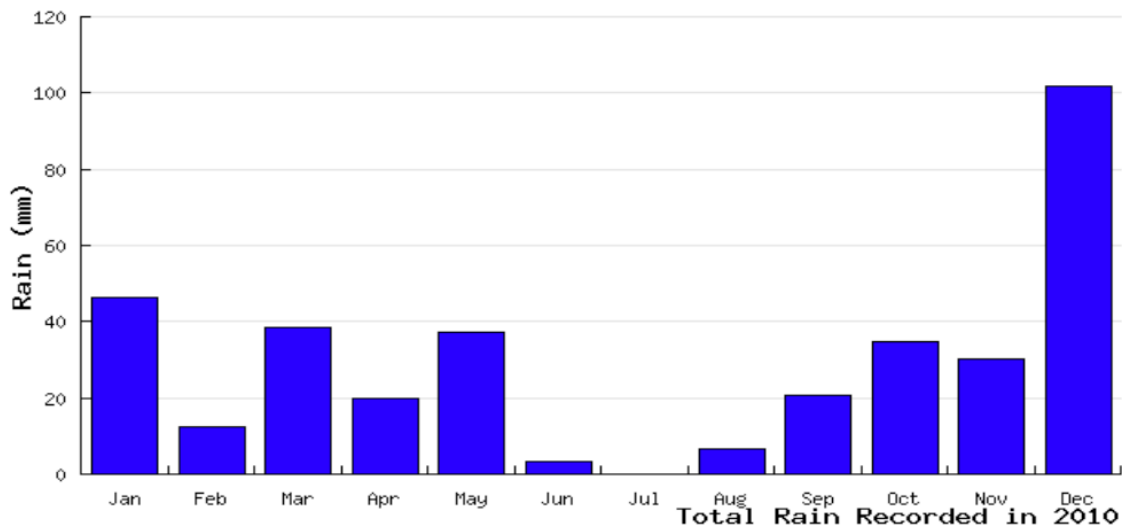

*Total annual rainfall recorded at Weather Station X*

Another way of presenting rainfall figures is by drawing lines on a map to link all places that receive the same amount of rainfall. These lines are called isohyets. They are usually drawn at uniform intervals.

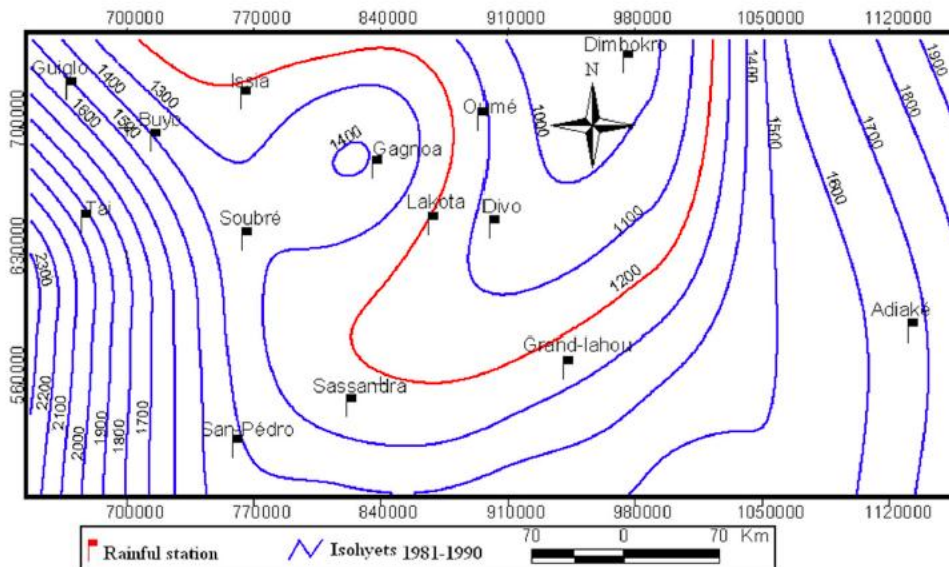

### *Isohyets*

#### Importance of precipitation

Precipitation, especially rainfall, plays an important role in weathering of rocks. It dissolves the chemicals in rocks, thus helping to peel them apart. This action is called weathering. The weathered rocks in turn form the soil. Weathering is particularly influenced by temperature and rainfall.

Some sports such as skiing, skating, etc take place on frozen snow. Therefore, snow as a form of precipitation, acts as a playground on which numerous games and sports can take place.

Rain provides us with the water we need for various uses such as irrigation, drinking, washing, cleaning, etc. When it rains, water collects into streams and rivers from where it is collected, purified and supplied to homes for various purposes. Rain can be harvested directly as it falls from the sky. It is then stored in tanks for later use. Rain water is natural, pure and can be used without any further purification.

Rain is an important component of the water cycle and is responsible for depositing most of the fresh water on the earth. It provides suitable conditions for many types of ecosystems, as well as water for hydropower plants.

## **Humidity**

Humidity is the state of the atmosphere in relation to the amount of water vapour it contains. Humidity indicates the degree of dampness of the air, and is one of the main influences on weather. It is expressed in either absolute or relative terms. Absolute humidity is the actual amount of water vapour present in a certain volume of air at a given temperature, expressed in grams per cubic metre. Relative humidity is the amount of water vapour present in a mass of air, expressed as a percentage of the total amount of water vapour that would be present when that air is saturated at that temperature. Air is saturated when the atmosphere cannot hold any more water vapour. This condition depends on the temperature and pressure of the air.

Humidity is measured by an instrument called hygrometer, which consists of wet and dry bulb thermometers. The wet bulb thermometer is kept moist (wet) by wrapping it in a muslin bag which is dipped in a container of distilled water. When the air is not saturated, water evaporates from the muslin and this cools the wet bulb causing mercury to contract. The dry bulb is not affected in the same way. So the two thermometers show different readings. But when the air is saturated the two thermometers show the same readings. Therefore, when there is a big difference in readings between the two thermometers, humidity is low and when there is a small difference, humidity is high.



*A hygrometer*

The hygrometer consists of dry (left) and wet (right) bulb thermometers. Can you notice a muslin bag dipped in a container of water?

Absolute humidity is calculated after finding the dew point. Dew point is the critical temperature at which air becomes saturated with water vapour. Further condensation causes the formation of tiny drops of water called dew.

Atmospheric pressure

The air around us has weight. Atmospheric pressure (or air pressure) is the weight of the air resting on the earth's surface. It is the weight exerted by air on the earth's surface.

The force with which air presses down on a unit area is called atmospheric pressure. But this pressure is exerted equally in all directions. Atmospheric pressure can be demonstrated by the following experiment:

Take a glass full of water, cover the top of the glass with a piece of thin paper, and then hold the glass upside down. The water in the glass will not spill out because pressure of the air is pressing the paper so that it does not fall out.

Atmospheric pressure is measured by an instrument called a barometer. There are two types of barometers, mercury barometer, and aneroid barometer. Mercury barometer measures pressure in millimetres, usually expressed symbolically as mmHg, read as millimetres of mercury. The pressure at sea level is 76 mmHg. This is called standard pressure.

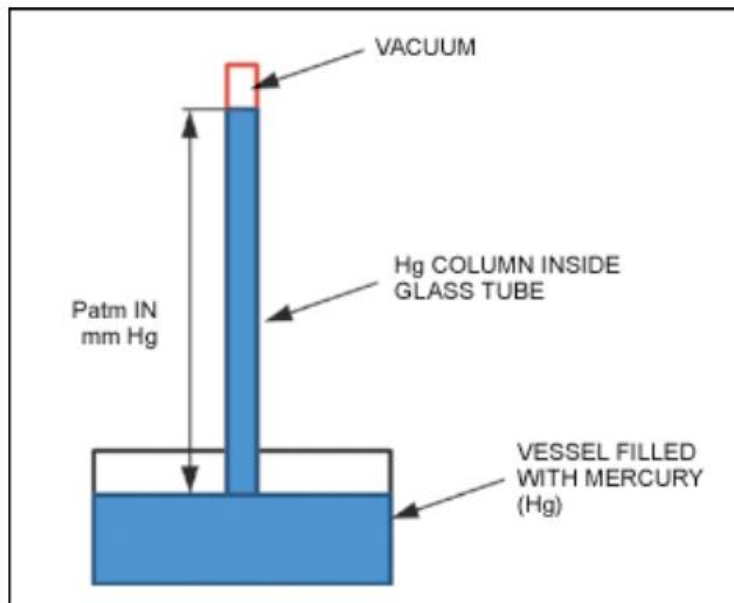

*Simple mercury barometer*

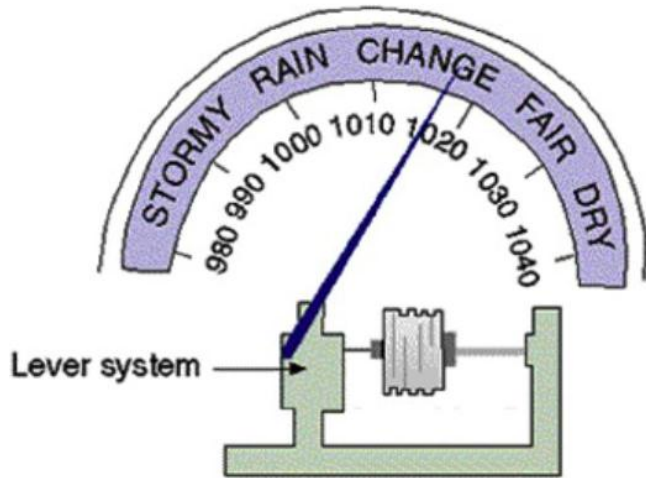

*Aneroid barometer*

Pressure is expressed in millimetres with reference to the height of mercury column. When using an aneroid barometer we express pressure in millibars of force per unit area. In physics, a unit of force known as a “dynes” per square centimetres is called a “bar” and is now the standard unit of pressure measurement. A bar is then divided into one thousand units called millibars. At sea level, pressure is normally 760 mmHg or 1.034 kilograms of force per square centimetre. This is equivalent to 1015.9 millibars or approximately one bar.

The diagram below shows the height of mercury column at high and low pressures. When the atmospheric pressure is high, mercury level is pushed up the glass tube. At low pressures, mercury column drops down.

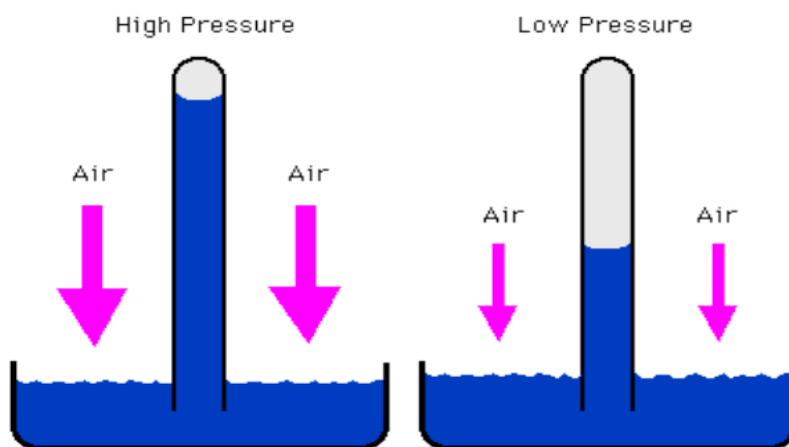

Pressure is shown on a weather map, usually called synoptic map. Lines drawn on a weather map joining places with the same pressure are called isobars.

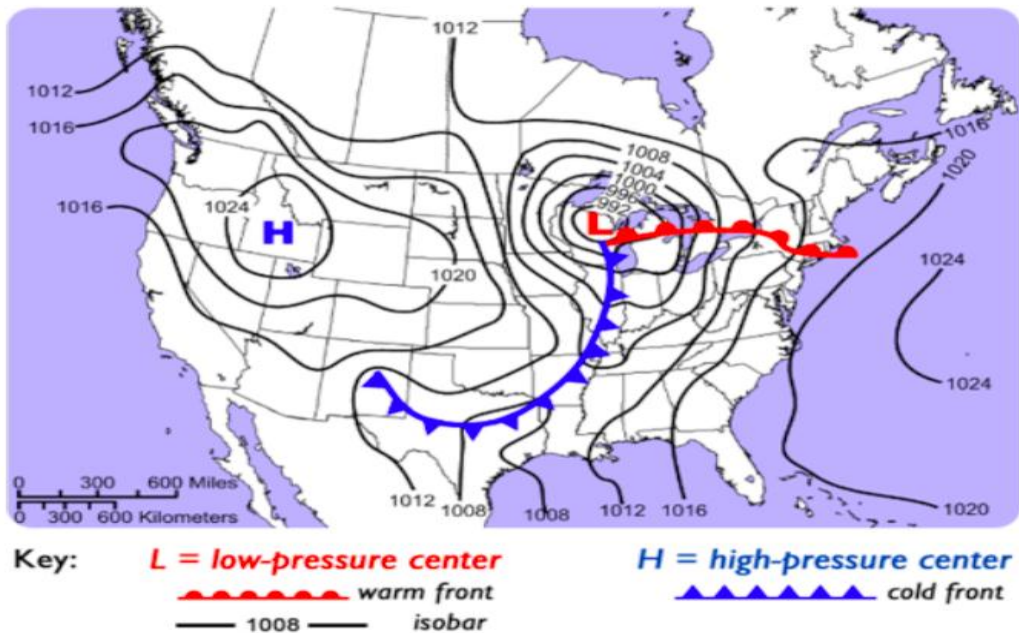

### Isobars

The pressure is greatest at sea level where the whole thickness of the atmosphere exerts its weight. But pressure decreases at the rate of 10 millibars for every 100 metres increase in height. This is because the thickness of the atmosphere decreases, thus it exerts less pressure.

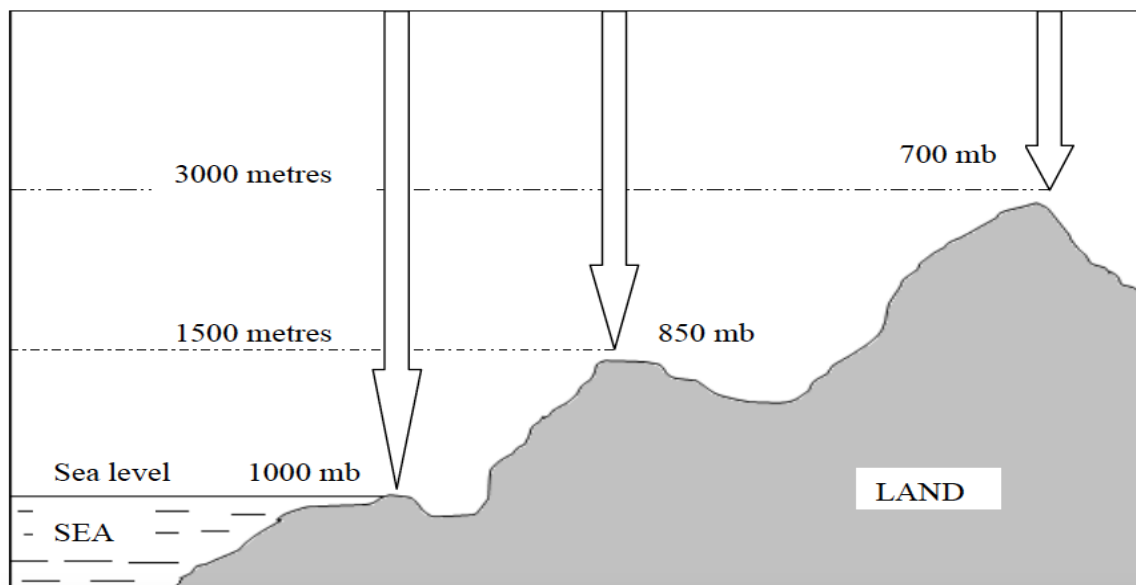

*Relationship between pressure and altitude*



## **Winds**

Wind is the movement of air masses especially on the earth's surface. Heated air expands, becomes less dense and rises up. Cooled air contracts, becomes denser and sinks down. When air sinks, its pressure increases because it is compressed, but when air rises, its pressure decreases because its molecules are spread over a large area. Areas from where heated air is rising are called areas of low pressure, while areas in which cool air is sinking are called areas of high pressure.

Usually, there is a movement of air from high pressure to low pressure areas, which is caused by differences in heating of air over different parts of the earth's surface. The air that moves from a region of high pressure to that of low pressure is called wind. Wind is air in motion, from high pressure areas to low pressure areas.

During the day the land is usually warmer than the sea, and the air pressure on the land is lower than that over the sea. Therefore, air blows from sea to land. This kind of air movement (wind) is known as sea breeze. But during the night the land is cooler than the sea and there is low pressure on the sea. Therefore, winds blow from the land to the sea. This air movement is called *land breeze*.

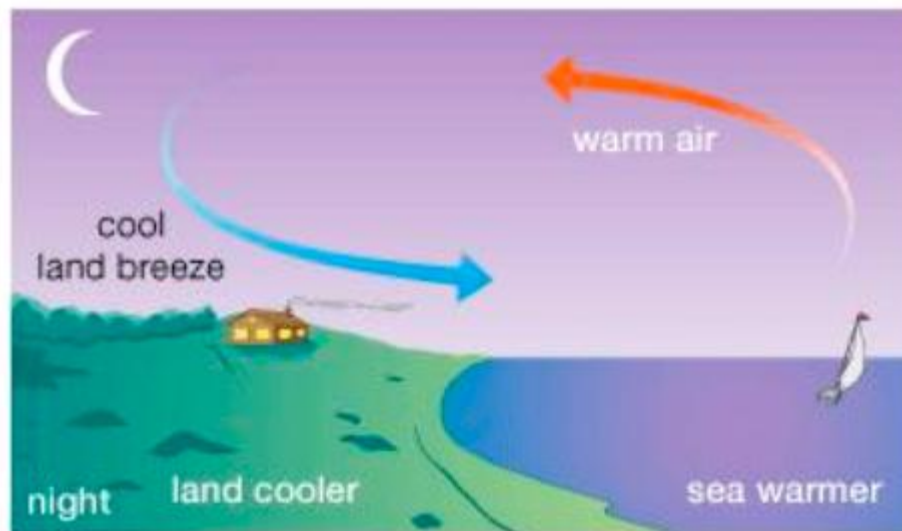

*Sea breeze (day) and land breeze (night)*

On the Earth's surface, the regions of the north and south poles are very cold and have high pressure while the belt along the equator is very hot and has low pressure. This makes air move from the poles towards the equator. In the equatorial belt, rising air is replaced by air moving in from the north and south of the equator. We should then expect two belts of wind blowing towards the equator. But this is not exactly so because the earth rotates from west to east, and according to Ferrel's law air or water moving freely in any direction over the Earth's surface is turned (deflected) to the right of its course in the northern hemisphere and to the left in the southern hemisphere. Therefore, any winds blowing from the north towards the equator in the northern hemisphere will blow from the north east and not from the north, and any winds

blowing from the south towards the equator in the southern hemisphere will blow from the south east and not from due south.

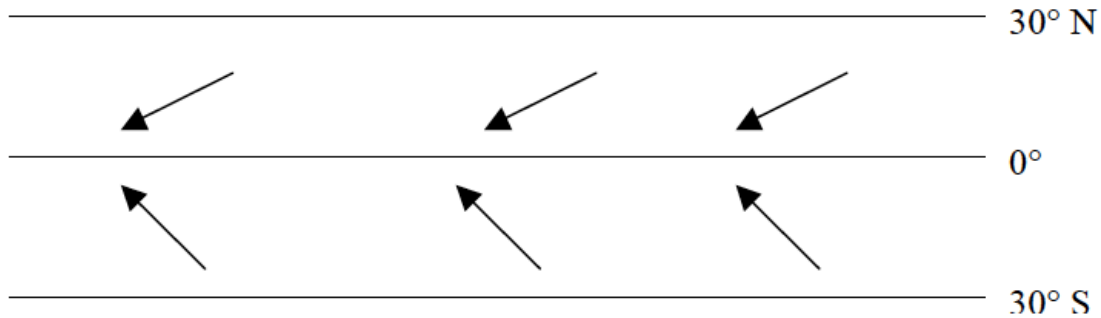

*Winds blowing from NE and SE*

In the equatorial belt of low pressure, between 5°N and 5°S latitudes, intense solar heating causes the moist air to rise in great convection columns. This belt is called the doldrums or low pressure belt. The rising air spreads out and moves towards the poles. In so doing, it cools and thus contracts, and develops high pressure. This occurs around 30°N and 30°S. Thus, the air sinks and builds up high pressure at these latitudes. These latitudes are called horse latitudes or subtropical high pressure cells.

In latitudes 30°N and 30°S some of the high pressure air moves over the surface towards the equator as the north east and south east trade winds. Some moves over the surface towards the poles as westerlies.

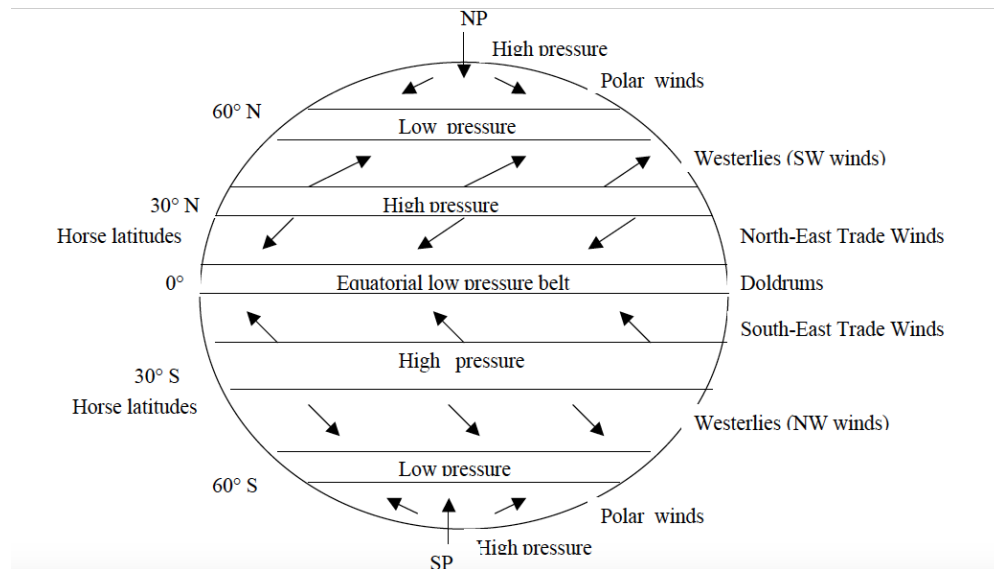

### *Wind belts of the world*

In each hemisphere, there are three wind systems which operate between the indicated latitudes:

- *The Polar wind system* (between the North Pole and 60°N; and between the South Pole and 60°S).
- *The tropical wind system* (between 30°N and 60°N; and 30°S and 60°S).
- *The equatorial wind system* (between 30°N and 30°S).

Occasionally in the westerly wind system, depressions and anticyclones develop. A depression is an area of low pressure in which winds blow inwards in a circular motion. This motion is anti-clockwise in the northern hemisphere and clockwise in the southern hemisphere. A depression develops when cold heavy air comes in contact with warm moist air. Depressions are usually associated with cyclonic rains. Anti-cyclones are areas of high pressure in which winds blow in a clockwise, circular motion in the northern hemisphere. They are associated with cool fine weather with no rain and they normally follow a depression.

Wind direction is measured by a wind vane or wind sock.

The wind vane consists of a freely rotating arm, fitted over a central rod. The arrow of the wind vane always points in the direction from which the wind blows, and the wind is named after this direction. Four arms marking the direction of the cardinal points are fixed to the stationary central rod.

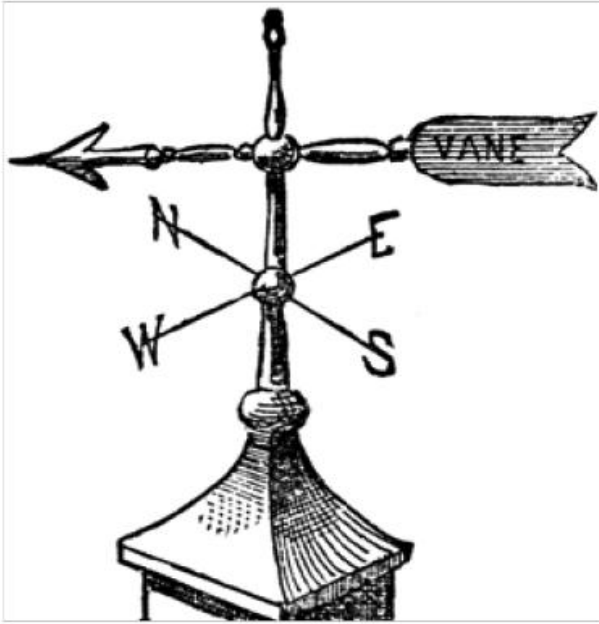

*A wind vane*

Wind sock consists of a sock-like sheet of cloth fitted to top of a tall wooden or metal bar, just like the flag is fitted to the flag post. The tail of the sock points away from the direction of wind, and the direction of wind is named after the head of the sock.

Wind socks are mainly used to show wind directions at airports and airstrips in order to direct pilots when landing or taking off.



*Wind sock*

Wind speed is measured by an instrument called an anemometer. This instrument consists of three or four horizontal arms pivoted on a vertical shaft. Metal caps are fixed to the end of the arms so that when there is a wind the arms rotate. This movement operates a meter which records the speed of wind in kilometres per hour.

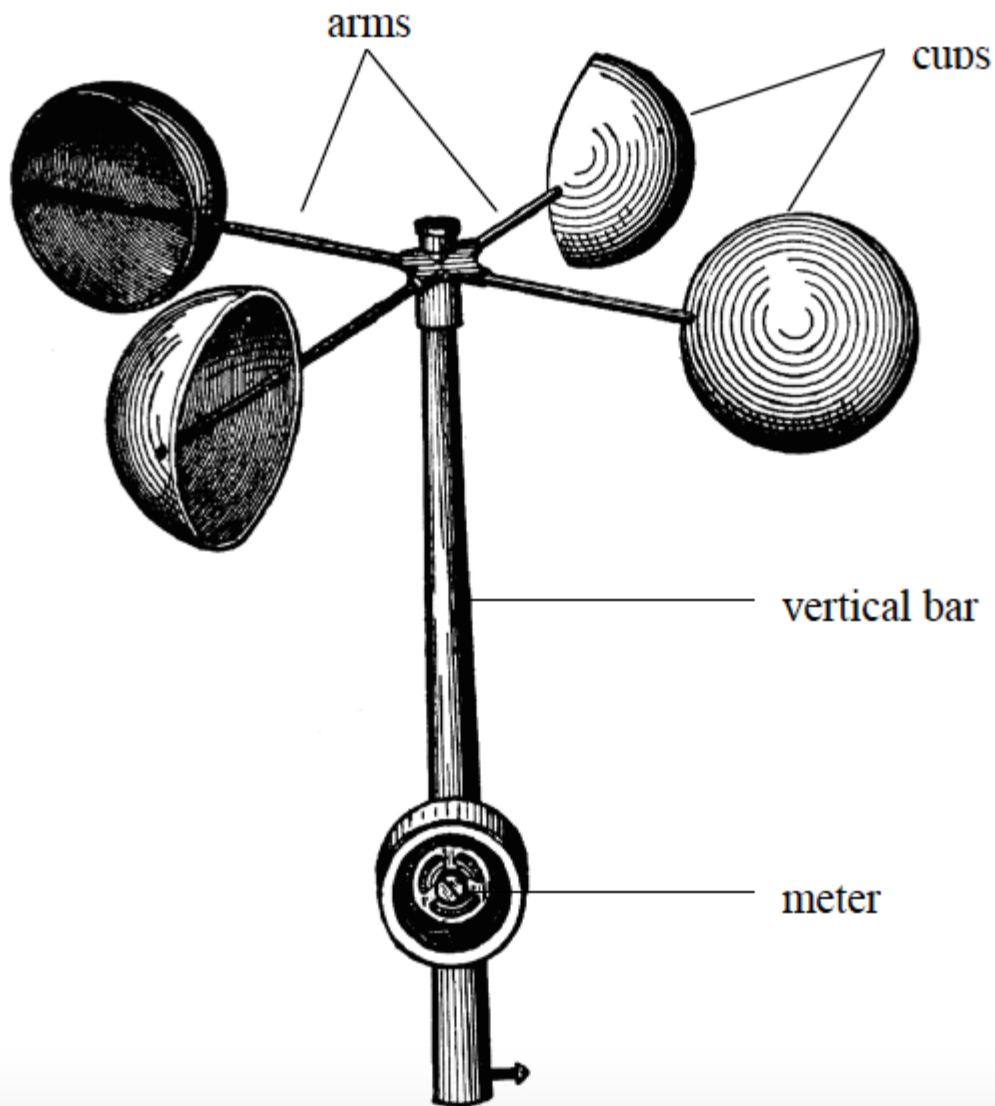

*Anemometer*

## **Cloud cover**

Cloud cover (also known as cloudiness, cloudage or cloud amount) refers to the fraction of the sky obscured by clouds when observed from a particular location. The cloud cover is observed

by using eyes. There is no special instrument for recording the cloudiness. Okta is the usual unit of measurement of the cloud cover. One okta represents approximately 1/8 of the sky with cloud cover. If approximately 3 segments out of 8 are covered in clouds, then the cloud cover is written as 3/8 cloud cover. These are 3 oktas. 8/8 means the cloud is completely covered by clouds. The figures below represents the symbols used to represent cloud cover in oktas.

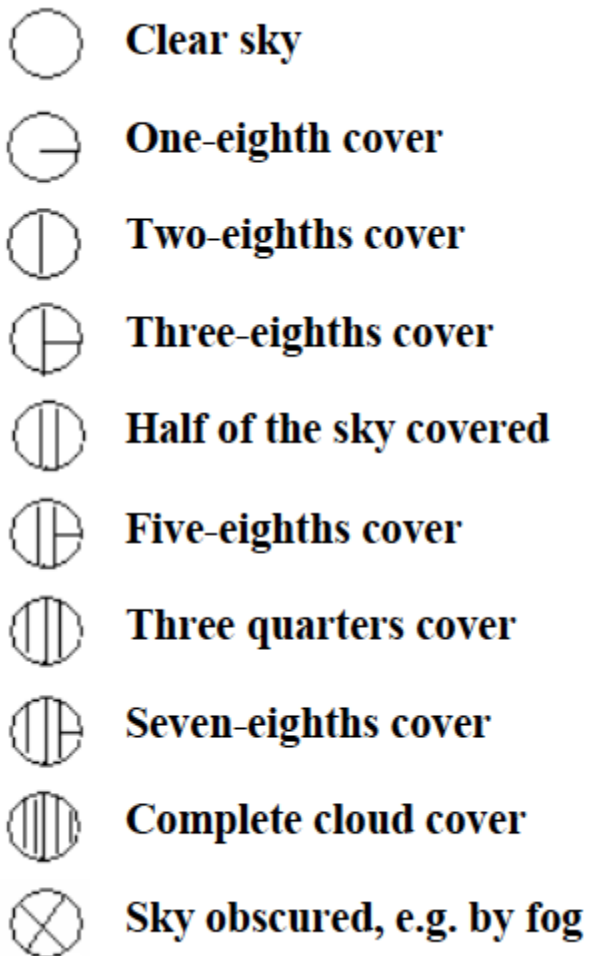

*Symbols used to show cloud cover*

Simple observation can be made such as:

- Clear - no cloud cover.
- Partly cloudy - less than half cloud cover.
- Mainly cloudy - more than half cloud cover but with some breaks in the cloud.

- Overcast - complete cloud cover.

## Sunshine

The amount of sunshine we have depends on latitude and how much cloud there is in the sky. In some of the world's deserts the number of sunshine hours is very high, more than 3,600 hours each year. In the Eastern Sahara desert, the sun is covered by clouds for less than 100 hours a year.

Hours of sunshine are usually recorded on a simple machine called a parheliometer also known as a Campbell-Stokes recorder.

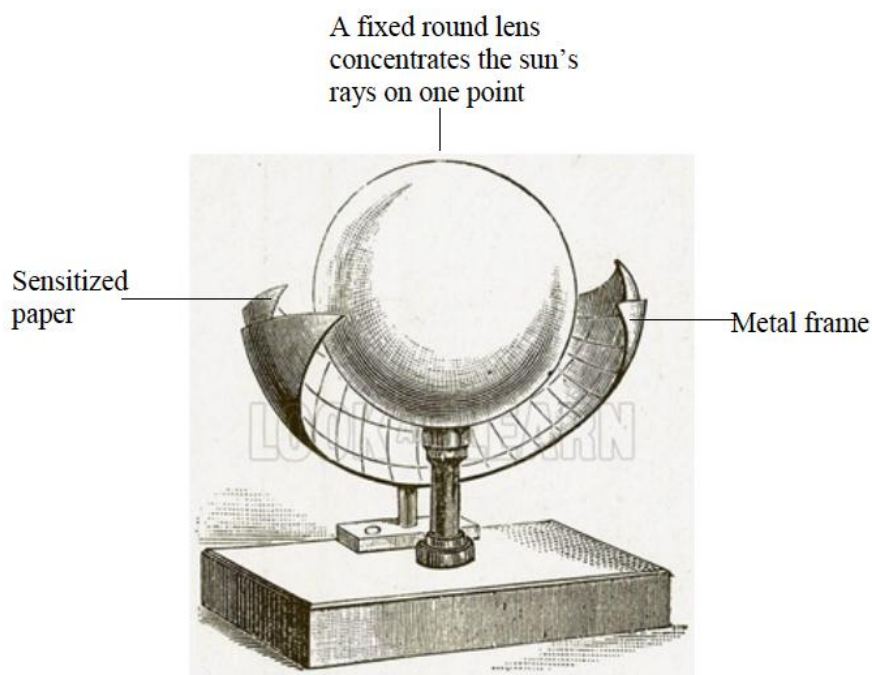

### *Campbell's Sunshine Recorder*

It works by using a glass ball to focus the sunlight and rays onto a strip of card. As the sun moves round during the day, the card is scorched, creating a record of how many sunshine hours there were.



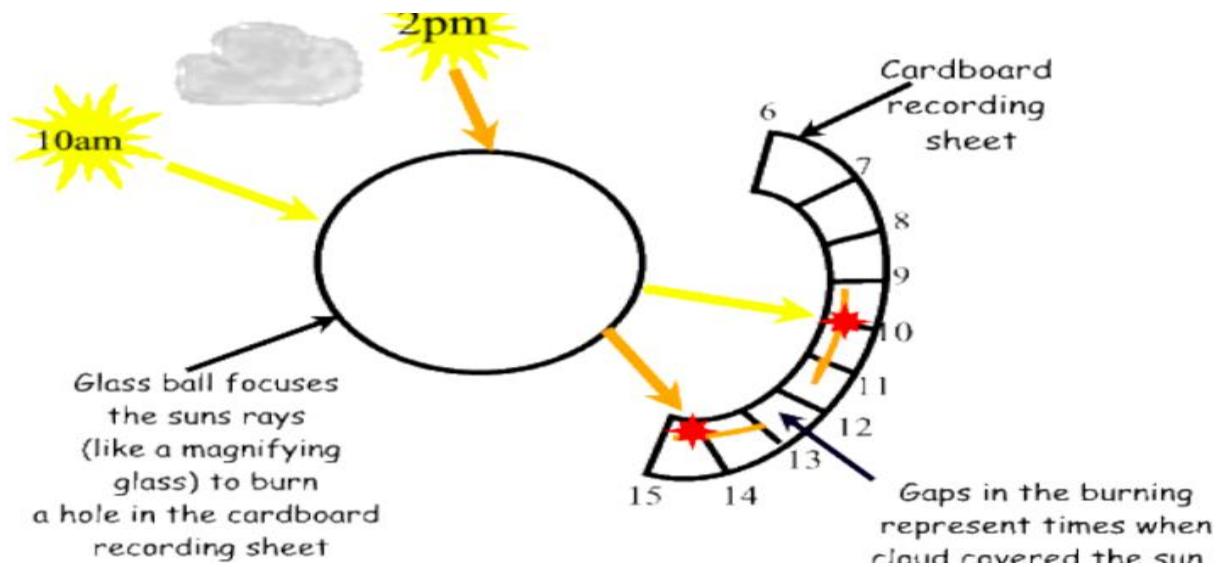

### Importance of sunshine

The energy from the sun can be trapped, harnessed and put into various uses including cooking, heating, lighting and operating machines. It also affects the amount of heat received on the earth. When the sun shines for many hours, the temperature of the earth rises and when there is no sunshine the temperature drops down.

The sun's energy is used by green plants to make their own food through the process of photosynthesis. Solar energy is also used to dry crops, clothes, etc. Our skins are also capable of converting the solar energy into vitamin D.

### Evaporimeter

An evaporimeter is an instrument used to measure the speed and amount of evaporation of water from the surface of the earth. There are two types of evaporimeters:

**Tank evaporimeter**—measures evaporation from an open and free water surface. The tank is filled with water to a known level and then exposed in an open area which is free from obstructions where water is left to evaporate. The water level is measured using a micrometer screw gauge. Any reduction in the level of water is because of evaporation.



*Tank evaporimeter*

**Piche evaporimeter**—measures evaporation from a continuously wet and porous surface.

## Importance of Elements of Weather

*Explain the importance of each element*

### **Importance of temperature**

- Temperature is an important factor in rain formation. Temperature causes the evaporation of water vapour from water bodies, land and plants. The resulting water vapour then condenses to make clouds that form rain.
- Temperature is the main factor in the creation of wind. When the sun heats the earth's surface unevenly, the resulting changes in temperature create changes in pressure and density. The ultimate result of these changes is the movement of air from a region of high pressure (cold area) to an area of low pressure (heated area). This movement of air is called wind.

- Plant growth and development is also highly influenced by temperature. It affects transpiration, seed germination and the rate of photosynthesis in different ways.
- Temperature controls planting dates and the growth of plants as well as insect pests and crop diseases. As an integral part of weather, temperature also determines the type of precipitation that might occur if you are in a location that is experiencing near freezing.

## Weather Station

### Meaning of Weather Station

#### *Define weather station*

A weather station is a facility, either on land or sea, with instruments and equipment for measuring atmospheric conditions to provide information for weather forecasts and to study the weather and climate. The measurements taken include temperature, barometric pressure, humidity, wind speed, wind direction, and precipitation amounts.

Wind measurements are taken with as few as other obstructions as possible, while temperature and humidity measurements are kept free from direct solar radiation, or insolation. Manual observations are taken at least once daily, while automated measurements are taken at least once an hour. Weather conditions out at sea are taken by ships and buoys, which measure slightly different meteorological quantities such as sea surface temperature, wave height, and wave period.

Weather station data can be used to gauge current weather conditions and to predict the future weather forecast, like temperature high/lows, cloud cover and probability of precipitation. Weather stations are used by meteorologists, weather buffs, gardeners, farmers, outdoor enthusiasts, students, pilots and anyone who enjoys weather data or relies on the weather to make decisions.

### How to Establish Elements of Weather

#### *Explain how to establish elements of weather*

Selecting an appropriate site for the weather station is critical for obtaining accurate meteorological data. Typically, the site should represent the general area of interest, and be away from obstructions such as buildings and trees.

When establishing a weather station the following guidelines must be considered:

1. The station should be located on an open space with free circulation of air.
2. There should be a wide view of the surrounding landscape and the sky.
3. The site should be free from obstructions by trees, buildings, mountains, etc. The station should not be under the shadows of objects. The open areas should be covered by short grass, or where grass does not grow, the natural earth. Avoid large industrial heat sources, rooftops, steep slopes, sheltered hollows, high vegetation, shaded areas, swamps, areas where snow drifts occur or low places holding stagnant water after rains.
4. The ground should be plain or gently sloping at a gradient not more than 5°.
5. The station should be fenced to keep off intruders, trespassers and passers-by and should always be locked. Only authorized people should have access into the station.
6. The geographical location of the station should be established by placing a compass in the station. This will help in determining the direction of wind shown by a wind sock /vane put in the station.



*A weather station*

## Characteristics of a Stevenson Screen

*Describe characteristics of a Stevenson screen*

A Stevenson screen or instrument shelter is an enclosure intended to shield meteorological instruments against precipitation and direct heat radiation from outside sources, while still allowing air to circulate freely around them. It forms part of a standard weather station.





*Exterior of a Stevenson screen*

## Characteristics and Functions of Instruments Used to Measure the Elements of Weather

*Describe the characteristics and functions of instruments used to measure the elements of weather*

The Stevenson screen holds instruments that may include thermometers (ordinary, maximum/minimum), a hygrometer, a psychrometer, a dew cell, a barometer and a thermograph. Its purpose is to provide a standardized environment in which to measure temperature, humidity, dew point and atmospheric pressure.

The traditional Stevenson Screen is a box shape, constructed of wood, in a doublelouvered design. However, it is possible to construct a screen using other materials and shapes, such as a pyramid. The World Meteorological Organization (WMO) agreed standard for the height of the Stevenson Screen is between 1.25 m and 2 m above the ground.



*Interior of a Stevenson screen*

The siting of the screen is very important to avoid data degradation by the effects of ground cover, buildings and trees. It is recommended that the screen be placed at least twice the distance of the height of the object, e.g., 20 m from any tree that is 10 m high. In the northern hemisphere, the door of the screen should always face north so as to prevent direct sunlight on the thermometers. In polar regions, with twenty-four hour sunlight, the observer must take care to shield the thermometers from the sun and at the same time avoiding a rise in temperature being caused by the observer's body heat.

The general purposes of the Stevenson Screen are:

- to ensure the safety of the delicate instruments kept in it which could easily be damaged if kept in the open air;
- to ensure accurate measurements of the meteorological data; and
- to protect instruments against precipitation and direct sunlight and heat, while still allowing air to circulate freely around them.

## Measuring Elements of Weather

*Measure and record elements of weather*

## Activity 1

Measure and record elements of weather

### The Meaning of Weather Forecasting and How it is Done

*Describe the meaning of weather forecasting and how it is done*

Weather forecasting is the application of science and technology to predict the state of the atmosphere for a given location.

### Weather forecasting methods

The nature of modern weather forecasting is not only highly complex but also highly quantitative. There are several different methods that can be used to create a forecast. The method a forecaster chooses depends upon the experience of the forecaster, the amount of information available to the forecaster, and the level of difficulty that the forecast situation presents. The various methods used in forecasting the weather are as follows:

#### Numerical method

More recently it has been realized that other methods can more accurately predict the future weather than was possible in the past. The numerical method involves a lot of mathematics. This method is based on the fact that gases of the atmosphere follow a number of physical principles. If the current conditions of the atmosphere are known, these physical laws may be used to forecast the future weather.

Numerical weather forecasting is made possible by making observations of the atmosphere by means of radiosonde stations all over the world. A radiosonde is a small weather station coupled with a radio transmitter. The radiosonde is attached to a helium or hydrogen-filled balloon, generally called a weather balloon, and the balloon lifts the radiosonde to altitudes exceeding 30 km. During the radiosonde's ascent, it transmits data on temperature, pressure, and humidity to a sea-, air-, or land-based receiving station. Often, the position of the radiosonde is tracked through GPS, radar, or other means, to provide data on the strength and direction of winds aloft. Thus the radiosonde flight produces a vertical profile of weather parameters in the area above which it was launched.



At precisely the same time each day (0000 and 2400 UTC), weather personnel across the planet release radiosondes to the sky. The data obtained are processed, correlated with data from other radiosondes, and used to create an instantaneous picture of weather conditions throughout the world. The data are used not only to understand current weather patterns but also as inputs for longer-range computer-based forecasting models.



*A radiosonde*

### Satellites

Radiosonde data are supplemented by means of radiometric observations from satellites which also provide data on humidity and cloud cover. For viewing large weather systems on a worldwide scale, weather satellites are invaluable. Satellites show cloud formations, large

weather events such as hurricanes, and other global weather systems. With satellites, forecasters can see weather across the whole globe: the oceans, continents, and poles. Recent satellite data is very detailed, even to the point of showing states and counties.

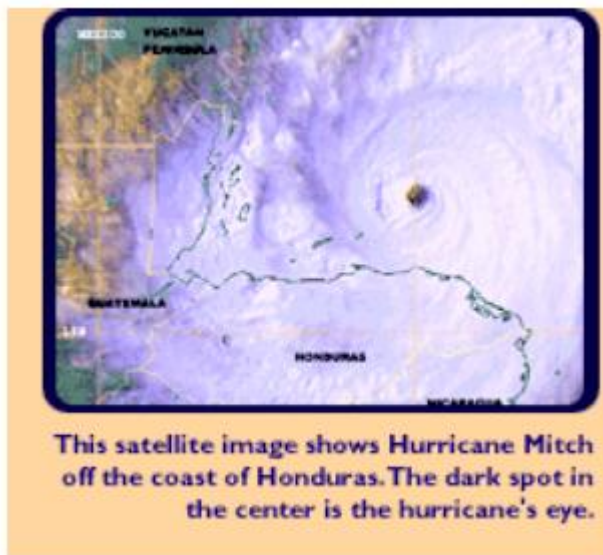

#### Persistence method

This is the simplest way of producing a forecast. This method assumes that the conditions at the time of the forecast will not change. For example, if it is sunny and 30°C today, the persistence method predicts that it will be sunny and 30°C tomorrow. If ten millimetres of rain fell today, the persistence method would predict ten millimetres of rain for tomorrow.

#### Trends method

This method involves determining the speed and direction of movement for fronts, high and low pressure centres and areas of clouds and precipitation. Using this information, the forecaster can predict where he or she expects those features to be at some future time. For example, if a storm system is 100 kilometres west of your location and moving to the east at 20 kilometres per day, using the trends method you would predict it to arrive in your area in 5 days.

#### Climatology method

The Climatology Method is another simple way of producing a forecast. This method involves averaging weather statistics accumulated over many years to make the forecast. For example, if you were using the climatology method to predict the weather for Dar es Salaam on July 4th, you

would go through all the weather data that has been recorded for every July 4th and take an average. If you were making a forecast for temperature and precipitation, then you would use this recorded weather data to compute the averages for temperature and precipitation.

If these averages were 33°C with 0.18 inches of rain, then the weather forecast for Dar es Salaam on July 4th, using the climatology method, would call for a high temperature of 33°C with 0.18 inches of rain. The climatology method only works well when the weather pattern is similar to that expected for the chosen time of year. If the pattern is quite unusual for the given time of year, the climatology method will often fail.

## **Importance of weather forecasting**

Weather forecasters alert farmers of the prospects of and amount of rainfall that is expected in a particular area. This enables them to decide what kind of crops to grow. If the forecast indicates little rainfall, then the farmers are advised to grow crops that resist drought or those that take a short time to mature. It, therefore, enables farmers to plan their farming activities well and in advance.

Weather forecasts and warnings are the most important services provided by the meteorological profession. Weather warnings are also important because they are used to save lives and protect property. The forecast saves lives and prevents the destruction of properties. For example, forecasters often warn people about the coming of extreme weather events such as tsunamis, earthquakes, floods, hurricanes or strong winds so that they can vacate their residence to save lives and property. This also enables people to get prepared to face the aftermath of these extreme weather events. In severe weather situations, short-term forecasts and warnings can help save lives and protect property.

Natural disasters such as hurricanes and tornadoes result from certain weather pattern combinations and can injure or kill thousands of people depending on their scope. These disasters often do lasting damage to cities and ecosystems as well. Because of this, being able to predict and understand weather patterns is a very useful skill when preparing for disaster.

Forecast based on temperature and precipitation is very important to agriculture and therefore to traders purchasing, transporting and selling agricultural produce.

Sailing and air travel are also highly controlled by the weather. We often hear of cancellation of air and sea travels due to harsh weather conditions. Accurate weather forecast therefore enables the marine and air transport personnel to schedule their travels in advance.

On everyday basis, people use weather forecast to determine what clothing to wear on a given day. Since outdoor activities are severely curtailed by heavy rain, snow and wind, forecast can be used to plan activities around these events and prepare to survive them.

## **Weather forecasting in Tanzania**

In Tanzania, weather forecast is conducted by Tanzania Meteorological Agency (TMA). This is a government body responsible for weather forecasting and dissemination of forecasting information to the general public. The agency forecasts weather on daily basis and alerts the public about the prospects, intensity and the expected consequences likely to be caused by weather phenomena such as rainfall, storm, sea waves, atmospheric pressure. Information about the forecast is used by the government to protect life and property. It is also used by individuals to plan a wide deal of their daily activities.

# CLIMATE

## The Concept of Climate

*Define the concept of climate*

Climate is the average weather conditions of an area observed and recorded over a long period of time (about 30 years).

The scientific study of climate is called climatology and a person who studies climate is called climatologist.

## Weather and Climate

### The Difference between Weather and Climate

*Differentiate between weather and climate*

There are marked differences between weather and climate. The table below summarizes these differences.

| <b>Weather</b>   | <b>Climate</b>  |
|--|---|
| Describes the atmospheric conditions at a specific place and time.   | Describes the average atmospheric conditions of a place over a specific period of time.   |
| Weather is defined as the day to day state of the atmosphere, and it is short-term (minutes to weeks) variation. | Climate is defined as statistical weather information that describes the variation of weather at a given place for a specified time interval. |
| Weather conditions are measured over a short period e.g. a few hours or days.                                    | Climate conditions are measured over many years, e.g., 30 years.  |
| Determined by real time measurements of atmospheric pressure, wind speed and direction, humidity, precipitation, | Determined by averaging weather data over periods of 30 years.  |

|  |   |
|--|---|
| cloud cover, and other variables.                          |   |
| Weather changes abruptly within a short period.            | Climate changes slowly and gradually over many years.                             |
| Weather varies from one place to another within a region.  | Climate remains uniform over a large area.  |
| Most weather elements are measured by weather instruments. | Climatic elements are not measured but calculated from the recorded weather data. |

## Factors influencing weather and climate

Usually, the elements of weather (which make up climate) vary from place to place. In the lesson on weather we learned about the elements of weather. Because climate is influenced by weather, the elements of weather are the same as the elements of climate. Therefore, the factors that cause variation in weather elements will likewise influence the climate. The factors influencing climate and weather are discussed below:

1. **Latitude:** This factor influences temperature and rainfall. Areas around and close to the equator experience higher temperature and receive higher rainfall than those farther away. So the rainfall and temperature decreases as one moves away from the equator. The amount of heat received at any place on the earth's surface depends on the angle at which the sun's rays strike the surface of the earth and the duration of the sunshine. At the equator, the sun's rays fall on the Earth's surface at almost right angles throughout the year, but the angle at which the sun's rays strike the Earth's surface decreases as one moves towards the poles. Therefore, temperatures decrease with increase in latitude because the equator receives vertical rays of sunlight while the north and the south poles receive slanting rays. Because of this fact, the equator and places near the equator are hotter while places in or near the south and north poles are colder.
2. **Altitude:** This influences temperature and atmospheric pressure of an area. Temperature decreases with increasing altitude at the rate of  $0.6^{\circ}\text{C}$  for every 10 metres rise in altitude. Therefore, low-altitude areas are warmer than high altitude areas. Atmospheric pressure decreases with increasing altitude. Pressure at sea level is higher than pressure at the summit of a high mountain.
3. **Ocean currents:** The nature of the ocean current influences the temperature of the wind blowing over it and transfers this influence to the land adjacent to the ocean. This will either lead

to reduction or increase in the temperature of the land depending on the type of the ocean current. The wind blowing over warm ocean currents will pick moisture from the ocean and often causes heavy rainfall over the land while the wind blowing over the cold ocean current brings little or no rainfall to the land.

4. ***Distance from the sea:***This influences temperature and rainfall. Places located near the sea experience high temperature and receive high rainfall than those located farther away. This is because of high rates of evaporation from the water surface, which eventually causes heavy rainfall along the coastal areas. For this reason, coastal regions often experience higher temperatures and rainfall than inland areas.

5. ***Aspect:***This term refers to the direction in which a slope faces. It influences temperature and rainfall. For example, the south facing slopes in the northern hemisphere are always warmer than the north-facing slopes. Also the windward side of the mountain receives heavier rainfall than the leeward side.

6. ***Wind and air masses:***Wind carries moisture with it as it flows. Warm wind blowing over a cold region warms the cold region over which it flows. However, if the wind is cold, it cools the region. Warm, moist wind blowing towards a cold, dry region may lead to formation of rainfall in the destination region. Cold, dry wind blowing over a dry region brings no rainfall and if the blowing is repeated over several years, it may cause aridity in that region.

7. ***Alignment of the coastline:***This refers to the arrangement of the region's coastline in relation to the direction of the wind. If the winds blow across the coastline they cause rainfall. If they blow in parallel to the coastline, they cause drought.

8. ***Intertropical Convergence Zone (ITCZ):***This is a low-pressure area around the equator. The moist winds meet within this region. Places farther away from this zone experience only one rainy season while places close to the zone experience two seasons of heavy rainfall. This is because the winds converge around this region twice a year.

9. ***Forests:***Areas covered with forests normally receive high rainfall as compared to those with little or no vegetation. This is because of high rates of evaporation and transpiration, leading to high humidity. Therefore, these areas often, receive high amounts of rainfall and have a modified climate.

10. ***Human activities:***A range of human activities such as agriculture, mining, transportation, construction, etc affects the climate. For instance, clearing of the forests to get land for

agriculture and settlement leads to the loss of biodiversity, making the land arid and unproductive.

## Impact of Climate

### Relationship between Climate and Human Activities

#### *Relate climate to human activities*

Climate has many impacts to human activities. Various economic activities conducted by man in different parts of the world are governed by the type of climate experienced in a particular region. For example, people living in deserts and semi-arid regions do not practice much agriculture because their environment does not favour crop cultivation or animal husbandry. In these regions, however, a very limited agriculture and animals rearing is conducted. The animals kept include camels, goats, sheep, donkeys and other hardy animals. Only drought resistant crops such as dates are grown in deserts and arid areas.

In tropical and equatorial regions, a lot of agriculture is carried out. The inhabitants of these regions take part in cultivation of crops and keeping of animals. Crops grown include cocoa, banana, horticultural crops and grains. The animals kept in these climatic zones include cattle, pigs, donkeys, horses, poultry and other farmyard animals. Specific types of various economic activities carried out in each climatic region will be discussed in detail in the section below.

## **THE MAJOR WORLD CLIMATIC REGIONS**

Different regions of the world experience different amount of temperature and rainfall. The differences in the amount of rainfall and temperature experienced in different regions of the world make them have different climatic characteristics. This gives rise to various climatic regions around the globe. Temperature and rainfall are the main elements that determine the type of climate. Both elements vary considerably from one region to another and form a basis for classifying climate. The five broad types of climate are hot, warm, cool, cold and arctic (very cold) climates. Each of these climates is further subdivided into different subtypes as it will be explained in detail below:



## HOT CLIMATES

These are the type of climates found within the tropics, mainly between 23° north and 23° south of the equator. Hot climates include the following climate sub types:

1. Equatorial climate
2. Tropical continental climate
3. Tropical monsoon climate
4. Tropical marine climate
5. Tropical desert climate

### Equatorial climate

The region is found approximately between 0° and 5° north and south of the equator. It may extend up to 10° north or south of the equator in some regions. Examples of areas found within this region include the Amazon basin (South America), and the Congo basin, the southern Ivory Coast, south Ghana, western coastal Nigeria, and eastern coastal Malagasy Republic (all in Africa).

### Climatic characteristics

- a. There are no marked seasons.
- b. High temperature throughout the year: - The annual temperature range is about 3°C. - The daily mean temperatures are about 26°C all the year round.
- c. The daily temperature range is rarely more than 8°C because of the thick cloud cover.
- d. Rainfall is heavy and is usually convection rain.
- e. Rainfalls usually occur in the afternoons and they are accompanied by lighting and thunder.
- f. Total annual rainfall is about 200 mm with two maxima (peaks).
- g. High humidity and intensive cloud cover throughout the year This climate can generally be described as hot and wet throughout the year, with a small annual temperature range.

Highlands located within the equatorial region have their temperatures modified by altitude. The temperature of some of these highland areas, e.g., the East African Highlands, is lowered to about 15°C. These regions are said to have a modified equatorial climate.

Variations on the basic type of climate occur in the highland regions of equatorial Africa. The climate of most of these regions has an equatorial rainfall pattern.

In areas such as the south-eastern Nigeria, Cameroon, the south-east Asian islands of Malaysia, Indonesia and the Philippines, the climate is equatorial monsoon because of the seasonal reversal of winds. This results in even heavier rainfall.

Human activities carried out in the equatorial climate region include shifting cultivation and plantation agriculture. Crops grown in this region include yams, cassava, maize, millet, sweet potatoes, sorghum, beans, water melons, bananas and groundnuts. Examples of areas where this type of farming is practiced include some parts of West Africa and Asia.

In plantation agriculture, crops such as cocoa, rubber and oil palms are grown on large scale farms. Most rubber plantations are found in Malaysia, Indonesia, Thailand and Sri Lanka. They are also found in Liberia. Cocoa plantations are found in Brazil and West Africa (Ghana, Nigeria and Ivory Coast). Oil palms are grown in Nigeria, Malaysia and Indonesia.

Rainforests are also common in equatorial regions. In Africa, the equatorial forests are found in the Democratic Republic of Congo (RDC), Gabon and some parts of West Africa.

Tropical continental climate

This climate is also known as Sudan type or Savannah climate. In the interior of the continents it is referred to as tropical continental climate.

**Location:** This climatic region occurs between 5°N and 15°N and 5°S and 15°S though it extends to 25° north or south of the equator. It is best developed in most parts of Africa, and some parts of South America, India and Australia.

Climatic characteristics

- a. Hot summers (32°C) and cooler winters (21°C).

- b. The annual temperature range is about 11oC.
- c. The highest temperatures occur just before the rainy season begins.
- d. Heavy rains, mainly convection, occur in the summer.
- e. Total annual rainfall is around 765mm, though this increases in the areas lying close to the equatorial climate region. Similarly, rainfall decreases towards the tropical deserts.
- f. Humidity is high during the hot, wet season.

This climate is characterized by tall grass and trees which are more numerous near the equatorial forest region. The savannah region is suitable for herbivores animals such as giraffes, elephants, buffaloes, rhino, zebras, antelopes, wildebeests and many other animals. There are also carnivorous animals such as lions, leopards, hyenas, etc. The region also supports a variety of species of birds, reptiles and insects.

People living in this region mainly engage in livestock keeping, cultivation and tourism. Also lumbering is practised. Many tourists come from foreign countries to view the wildlife that live in the vast grassland. Numerous national parks have been established in this region. In Tanzania, for example, there are established national parks such as Serengeti, Mikumi, Selous, Tarangire, Ruaha, Saadani, Ngorongoro, Katavi and Manyara.

The major crops grown in this region are maize, millet, groundnuts, beans, onions, cotton, tobacco, sugarcane, sisal, rice and coffee.

#### Tropical monsoon climate

The areas which mainly experience monsoon type of climate are South East Asia, Northern Australia, Southern China, and the Indian subcontinent. This type of climate is most marked in India.

#### Climatic characteristics

- a. Seasonal reversal of winds (monsoon winds); onshore during one season and offshore during another season.

- b. Onshore wind brings heavy rain to coastal regions while offshore winds bring little or no rain, except where they cross a wide stretch of the sea.
- c. Temperatures range from 32°C in the hot season to about 25°C in the cool season, giving an annual range of about 7°C.
- d. Annual rainfall varies greatly, depending on relief and the angle at which onshore winds meet the highlands (aspect).
- e. There are three marked seasons: cool, dry season; hot, dry season; and hot, wet season.

This climate can generally be described as having a hot, wet season and cool, dry season. The main human activities carried out in areas experiencing this type of climate include rice growing and livestock husbandry. Apart from rice, the other crops grown are wheat, millet, maize, and sorghum.

Sugarcane, cotton and juice are important lowland crops grown in India, Pakistan and Bangladesh. The other crops grown are tea (Sri-lanka, Bangladesh and India) and rubber in Malaysia. Animals kept in this climatic region include pigs, cattle, buffalos, sheep, goats, and poultry.

#### Tropical marine climate

Regions with this type of climate are located on the east coasts of regions lying between 10°N and 25°N and 10°S and 25°S. These areas are under the influence of onshore trade winds. The main areas are the east coasts of Brazil and Malagasy, the lowlands of central American and the west Indies the coast of Queen land (Australia) and the southern Islands of the Philippines.

#### Climatic characteristics

- a. Temperature characteristics are similar to those of the equatorial climate.
- b. Hot season temperature is 29°C and cooler season temperature is 21°C. (c) Annual temperature range is about 8°C.
- c. Total annual rainfall varies from 1000 mm to 200 mm depending on the location.
- d. Rainfall is both convection and topographic (brought by onshore trade winds).

- e. Maximum rainfall occurs in the hot season.
- f. High humidity throughout the year.

This climate can generally be described as hot and humid throughout the year. However, the climate is cooled by the onshore winds blowing almost everyday.

The main human activities carried out in this climatic region include crop cultivation, lumbering and animal rearing. The crops grown include sugarcane, rice, banana and wheat. The animals kept are such as cattle, pigs, sheep, goats and poultry.

#### Tropical desert climate

The tropical desert climate occurs on the western margins of landmasses between latitude 20° to 30° north and south of the equator. The climate is experienced in all the major tropical deserts of the world. The hot deserts occupy about one third of the earth's surface. The principal tropical deserts occur on the continents as follows:

1. Africa: Sahara, Kalahari and Namib Deserts.
2. Asia: the desert of Jordan, Syria, Iran, Iraq, Saudi Arabia and Israel, and the desert of India.
3. North America: Mohave, Colorado and Mexican Deserts.
4. South America: Atacama Desert.
5. Australia: Great Australian Desert

#### Climatic characteristics

- a. Very little total annual rainfall (less than 120 mm in any one year).
- b. Mean monthly temperatures range from 29°C in the hot season to 10°C in the cool season.
- c. In most deserts, daytime temperature can rise to as high as 47°C or more.
- d. Night temperatures can fall to as low as 16°C in summer and 5°C in winter.
- e. Very high diurnal temperature range (due to very hot days and very old nights).

- f. The annual temperature range is large. It is about 16°C.
- g. Humidity is always low and therefore evaporation is high.

Desert environments support very minimal human activities. Wherever water is available as in oases (singular oasis), and along rivers, agriculture is practised. The crops grown include date palms, cotton, rice, sugarcane, vines, millet, tomatoes, tobacco and fruits. Apart from the people who live permanently in oases, there are nomads who move from one place to another in search of pasture. They keep camels, donkeys, goats and sheep. The camel is an animal that has adapted to desert conditions. It can survive for many days without drinking water. It is mainly used for transport in the desert. Other desert people are good hunters and also collect food from the bushes.

The other activities that can be done by desert dwellers include weaving mats, making ropes, and trading.

#### WARM CLIMATES

Warm climates border the hot tropical deserts. They occur between 30° and 40° north and south of the equator.

There are four broad types of warm climates:

1. Warm temperature western margin;
2. Warm temperature continental;
3. Warm temperature eastern margin; and
4. Warm temperature desert.

Warm temperate western margin (Mediterranean type). This is also known as the Mediterranean climate

This type of climate occurs between 30°N and 45°N and 30°S and 40°S on the western sides of the continents. Places experiencing the Mediterranean climate are on the coastal lands around the Mediterranean Sea (the Maghreb, Spain, Italy, Greece, Egypt and Israel), the western sides of

north and South America (central California and central Chile), South Australia (Perth and Adelaide) and South Africa (Cape Province).

#### General characteristics

- a. Temperatures range from 21°C in the summer to 10°C (or below) in the winter.
- b. Mean annual temperature is about 15°C.
- c. Annual total rainfall varies from 500 to 900 mm.
- d. Hot, dry summers and cold, wet winters. This is because westerly winds blow off shore in the summer and on shore in the winter.

The Mediterranean climate can generally be described as having hot, dry summers and muggy, rainy winters. The climate permits a wide range of crops to be grown, which include fruits and cereals. It is in this region that much of the world's citrus fruits are grown. Citrus fruits include oranges, lemons, grapes and limes. Other fruits grown here are peaches, apricots, plums, cherries, olives, almonds and pears.

The cereals include maize, wheat, rice and barley. Agriculture has given rise to specialized industries such as wine-making, flour-milling, fruit canning and food processing industries.

#### Warm temperate continental (steppe type)

This type of climate is also known as warm temperate interior region.

**Location:** It occurs in the interior of the continents, between 20° and 35° north and south of the equator. The best examples of the areas having this climate are Murray-Darling lowlands of Australia; The high Veldt of South Africa; and the central Paraguay and central Argentina (both in South America); central lowlands of north America (Oklahoma and Texas and in northern Mexico); central European lowlands, and the plains of Manchuria.

#### Climatic characteristics

- a. Temperatures range from 26°C in the summer to 10°C in the winter.
- b. The annual rainfall varies from 380 to 700 mm, depending on the distance from the sea.

c. Rainfall is convectional type and falls mainly in spring and early summer. The main economic activities carried out in this region are cattle rearing and crop growing. Tourism is also practised.

Warm temperate eastern margin (China type)

**Location:** It occurs in the eastern sides of the continents between latitudes 23° and 35° north and south of the equator. The countries having this type of climate are central China, south eastern USA, southern Brazil, eastern part of Argentina, South Africa, southern Brazil, eastern part of Argentina, South Africa, southern Japan, and south eastern Australia.

Climatic characteristics

- a. Temperatures are about 26°C in summer and 13°C in the winter.
- b. The total annual rainfall varies is about 1000 mm.
- c. The rain is convectional and torrencial type and it mostly falls in the summer.

Temperatures and rainfall in this type of climate make it possible to grow crops and keep animals. Lumbering is also practised in the forested areas. The crops grown include rice, maize, cotton, sugarcane and tobacco. Animals are extensively kept in Argentina and Australia. The animals produce products such as meat, milk, butter and cheese for consumption and export.

Warm temperate desert

This type of climate is also called mid-latitude desert climate. The areas having this type of climate include Nevada and Utah states of North America and Patagonia in South America. It is also found in regions that extend from Turkey, northern Iran, across the Caspian sea and Aral areas into former USSR. It is also experienced in the Gobi desert of Mongolia.

## COOL CLIMATES

These climates are experienced in regions between 35° north and 60° south of the equator. They are characterized by definite seasonal variations in temperature. There are four types of cool climates:

1. Cool temperate continental (British type);
2. Cool temperate continental (Siberian type);



3. Cool temperate eastern margin (Laurentian type); and
4. Temperate desert.

#### Cool temperate western margin (British type)

It occurs on the western sides of the continents between 45° and 60° north and south of the equator. Areas with this type of climate include North West Europe, British Columbia in western Canada, Southern Chile, Tasmania, and the south Island of New Zealand.

#### Climatic characteristics

- a. Winter temperatures range between 2°C and 7°C, while summer temperatures range from 13°C to 15°C.
- b. The annual temperature range is between 8°C and 11°C.
- c. Rain falls throughout the year, with maxima in winter.
- d. The total annual rainfall is about 760 mm.
- e. The rain is both convectional and cyclonic in nature.

People living in this region engage in a myriad of economic activities which include agriculture, mining, lumbering, manufacturing and commerce. Agriculture is of extensive type and includes keeping of beef and dairy cattle and sheep and the growing of wheat, barley oats, vegetables and fruits. In British Columbia lumbering is an important economic activity. In Tasmania and New Zealand, sheep rearing for wool and mutton is an important activity. Fruit farming, especially apples, is practised throughout the region.

#### Cool temperate continental (Siberian type)

This type of climate is found extensively in the northern hemisphere. It occurs in the interiors of North America and Eurasia between 35° and 60°N

#### Climatic characteristics

- a. Moderately warm summers (18°) and very cold winters (-19°C).
- b. The annual temperature range is very high (37°C).

- c. Most of the rain falls in the summer.
- d. The rain is convectional type and is often accompanied with thunder.
- e. The annual precipitation (rain plus snow) ranges from 400 to 500 mm.

The main human activities in this region include lumbering fishing, mining and some agriculture.

Cool temperate western margin (Laurentian type)

It occurs on the eastern sides of the continents between 35°N and 50°N, and south of 40°S. It is experienced mainly on the eastern sides of North America and Asia.

Climatic characteristics

- a. Winter temperatures range from -10°C to 4°C.
- b. Summer temperatures range from 12°C to 24°C.
- c. The annual temperature range is large and averages 24°C.
- d. Precipitation (in the form of rain and snow) is distributed throughout the year.
- e. Annual precipitation varies between 700 and 1000 mm. (f) Rainfall is both convectional and cyclonic.

The main economic activities in this region are farming, mining, and manufacturing. The crops grown include wheat, maize, millet and soya beans. Sheep farming is important in Patagonia. Mining and manufacturing are practised where minerals are found.

Temperate desert

This climate occurs in the interiors of Eurasia and North America, and in Patagonia (South America).

Climatic characteristics

- a. Winters are very cold with temperatures often below -7°C.
- b. Summer temperatures vary between 25°C and 37°C.

- c. Diurnal temperature range is about 35°C while the annual temperature range is about 40°C.
- d. Precipitation is very low, it averages about 250 mm.
- e. Most of the rain falls in late winter and early spring.

The human activities carried out in this region include mining, animal rearing and some agriculture. The animals reared are such as camels, donkeys, sheep and goats. The main crops grown in this region are date palms, oil palms, and millet. Agriculture is mostly practised in oases and along river valleys.

### COLD CLIMATES

Cold climates are mainly experienced in regions between latitudes 60°N and 68°N

There are three types of cold climates:

1. Cold temperate western margin;
2. Cold temperate continental; and
3. Cold temperate eastern margin.

#### Cold temperate western margin

This climate is confined to coastal areas of Scandinavia and Alaska.

#### Climatic characteristics

- a. Short, cold summers with temperatures of about 12°C.
- b. Long winters with temperatures ranging from -2°C to 4°C.
- c. Annual rainfall is about 750 mm.
- d. Rain falls in most months except the winter when snow falls.

The main economic activities practiced in this region include agriculture, mining and manufacturing. Dairy cattle farming is mainly practiced in the Scandinavian countries such as Norway Denmark and Sweden.

### Cold temperate Continental

This climate occurs between 55°N and 68°N in the interior of America and Eurasia.

#### Climatic characteristics

- a. Cold and long winters with temperatures ranging between -34°C and -45°C.
- b. Warm and short summers with average temperatures up to 21°C.
- c. Annual precipitation is very low, about 380 mm. (d) Most of the rainfalls in summer, but in winter, precipitation is in the form of snow.

### Cold temperate eastern margin

This climate occurs in the north east pacific of Russia.

#### Climatic characteristics

- a. Long, cold winters with an average temperature as low as -20°C or below.
- b. Short, hot summers with an average temperature up to 21°C or higher.
- c. Total annual rainfall varies between 500 and 1000 mm.

## ARCTIC CLIMATES

These types of climates are experienced in regions beyond the Arctic Circle (66½°N) and around Arctic Ocean. They are also known as polar deserts. The main features of these climates are low amounts of precipitation (rain), mild summers and very cold winters.

Arctic climates comprises of Tundra and Polar climates

### Tundra climate

This region occurs in the northern coast of North America, southern coast Greenland and the Arctic coast of Europe and Asia.

#### Climatic characteristics

- a. Very long, cold winters with temperatures ranging between -29°C and - 40°C.
- b. Short, cool summers with temperatures of about 10°C.

c. Annual precipitation is 250 mm; some of it falls as snow in winter and as rain in summer.

#### Polar climate

It occurs in the interiors of Iceland, Greenland and Antarctica.

#### Climatic characteristics

- a. Temperatures are permanently below 0°C.
- b. Precipitation is in the form of blizzards (now storms).
- c. The winters consist of continuous night, and summers of continuous day.

Because temperatures are very low, most these regions are uninhabited and hence limited human activities take place here. The natural occupations are hunting, fishing and herding of reindeer.

#### Mountain climate

This type of climate occurs in the main mountain areas of the world. The areas that experience such climates include the East Africa Mountains, the Ethiopian highlands, the mountains and plateaus of central Asia, the Alps of Europe, the Andes of South America and the Rockies of North America.

#### Climatic characteristics

- a. Pressure and temperature generally decrease with increase in altitude.
- b. Precipitation increases with altitude.
- c. In areas around mountains within the tropic, temperatures may range from high at the foot of a mountain to very cold at the peak, e.g. Mount Kilimanjaro.

We have seen how particular climatic conditions influence human activities. Now, let us see how specific climatic conditions are suitable for given human activities.

#### Agriculture

Agriculture is strongly influenced by weather and climate. The nature of agriculture and farming practices in any particular location depends on the type of climate experienced in that location.

Crops thrive well in any area with a fertile soil and which receives sufficient rainfall as well as optimum temperature conditions. In such areas both commercial and subsistence crops may be grown.

The equatorial region receives high rainfall and experiences high temperature throughout the year. This climate is suitable for crops that can thrive well in moist and hot conditions. The crops that can be grown in this region include cocoa, banana, rubber, sugarcane and yams.

Livestock rearing can be practised in the tropics where rainfall permits the growth of pastures. This area also supports the cultivation of a variety of tropical crops such as fruits, tobacco, sugarcane, tea, maize, rice and a variety of horticultural and cereal crops

Cooler climates also support crops which grow better in climates like barley, wheat, oats, sugar beet, and fruits such as apples, peaches and apricots. These areas also support the rearing of dairy animals.

In semi desert and desert climates where very little rainfall is received, there are reduced agricultural activities. However, drought-resistant crops like millet, date palms, oil palms and sorghum can be grown. The keeping of hardy animals such as sheep, camels, donkeys and goats can be done.

### Settlement

People like to establish settlements in areas with favourable climates and which support a variety of agricultural activities. Such areas are often well-populated. Very hot or extremely cold areas are usually sparsely populated because their climatic conditions are unfavourable for human settlement.

Forests thrive well in areas that receive ample rainfall and which have adequate temperatures. Dense forests of the world are concentrated in the equatorial and tropical climates which experience high rainfall and temperature throughout the year. The presence of forests in these regions stimulate lumbering and growth of other industries such as paper-making and carpentry.

### Fishing

Most of the world's fishing grounds are in cooler regions. The cooler water is thought to support the growth of water plants called plankton on which fish feed. Tropical areas are not suitable for fish as compared to regions with temperate climates.

### Tourism

For tourism industry to flourish, the climate in the host countries must be favourable enough to attract the tourists to visit them. Tropical countries, like Tanzania, are often visited by tourists from cooler climates during winter in their home countries to enjoy the warmth of the tropical countries where they swim in warm waters and sunbath in tropical beaches.

Likewise, the tropical climate supports numerous wildlife which serve as tourist attractions. In Tanzania, for example, there are many national parks with thousands of wildlife species and beautiful sceneries. The animals found in the parks include elephants, buffaloes, zebras, lions, leopards, chimpanzees, monkeys and a variety of reptiles, amphibians, insects and plant species.

### Industry

The establishment and growth of industries strongly correlate to the climatic conditions. Most industries are established in areas where raw materials are adequately available. For instance, milk, tea, tobacco, meat, fish and fruit processing industries are often located where raw materials are found. Likewise, lumbering industries are built close to forests.

### Transport

Development of the transport systems in some climatic regions is very difficult. For example, the tropical and equatorial regions, which receive much rainfall throughout the year, have poorly developed roads. Routes passing through areas with clay soils become muddy and slippery when it rains. This makes it hard to travel on earthy and murrum roads. Roads in desert regions may be blocked by sand blown onto them, making the roads impassable. In very cold regions, precipitation in the form of snow may cover roads, making them impassable during winter.

## **CLIMATE CHANGE**

Climate change is a large-scale, long term shift in the planet's climate (weather patterns and temperatures). The overall effect of climate change is termed as global warming.

## Question Time 1

### *What is global warming?*

Global warming refers to increase of the earth's average surface temperature due to effects of the greenhouse gases. These gases trap heat that would otherwise escape from the earth. The greenhouse gases include water vapour (H<sub>2</sub>O), carbon dioxide (CO<sub>2</sub>), methane (CH<sub>4</sub>), dinitrogen oxide or nitrous oxide (N<sub>2</sub>O), ozone (O<sub>3</sub>) and chlorofluorocarbons (CFCs).

Since the early 20th century, the global air and sea surface temperature has increased by about 0.8°C, with about two-thirds of the increase occurring since 1980. Each of the last three decades has been successively warmer at the earth's surface than preceding decades since 1850.

The recent rapid warming was caused by human activities which contribute to the production of greenhouse gases, such as carbon dioxide, that trap heat in the earth's atmosphere. It is predicted that the continuation of these activities will result in 1.8–4°C average temperature increase over the next century.

### Causes of global warming

Scientific understanding of the cause of global warming has been increasing. Global warming is mostly caused by increasing concentrations of greenhouse gases in the atmosphere. The following greenhouse gases are the main contributors to global warming. They are the main causes of global warming.

### Carbon dioxide

Carbon dioxide is the main greenhouse gas. The gas contributes over 50% of the greenhouse effect. It is because of this reason that man is struggling to reduce carbon dioxide emissions. The following are some of the man-made sources of carbon dioxide in the atmosphere:

**Deforestation:** Green plants absorb carbon dioxide gas from the atmosphere and use it to manufacture their food through the process of photosynthesis. Cutting down trees means that a few trees are left to absorb carbon dioxide gas from the air. This has led to the increase in the amount of carbon dioxide in the atmosphere.





*A deforested land*

**Combustion of fuel:** Burning of fossil fuel such as wood, coal, petroleum and natural gas, releases carbon dioxide into the atmosphere. The gas is produced during combustion of these fuels in car engines, power stations, industries, etc.

#### Methane

The main source of methane is from agricultural activities. It is released from wetlands such as rice fields and from animals, particularly cud-chewing animals, like cattle. The emission of methane gas into the atmosphere, therefore, increases with increase in agricultural activities. Since 1960s the amount of methane in the air has increased by 1% per year, twice as fast as the build-up of carbon dioxide. Methane is also produced by the decomposition of waste materials by bacteria. It is the major component of natural gas. The gas is also produced during the mining of coal and oil (as natural gas) and when vegetation is burnt.

#### Nitrous oxide (dinitrogen oxide, $N_2O$ )

Dinitrogen oxide is produced from both man-made and natural processes. Human activities which produce dinitrogen oxide include combustion of fossil fuels in vehicles and power stations, use of nitrogenous fertilizers and burning of vegetation and animal waste. During combustion of fuel in automobile engines, the air gets so hot that nitrogen reacts with oxygen to form dinitrogen oxide.

The gas is also produced by digesting bacteria, and is part of the nitrogen cycle, one of the most important natural processes on earth.

#### Chlorofluorocarbons (CFCs)

The sources of CFCs in the atmosphere include refrigerators, air conditioners and aerosols. CFCs are extremely effective greenhouse gases. One CFC molecule is about 10,000 times more effective in trapping heat than a carbon dioxide molecule. Some of them are up to 14,000 times effective than carbon dioxide, the main greenhouse gas.

#### Effects of global warming

Global warming is expected to have far-reaching, long-lasting and, in many cases, devastating consequences for planet earth. The following are some effects of global warming:

##### Increase in average temperatures

One of the most immediate and obvious impacts of global warming is the increase in temperatures on the world. The average global temperature has increased by about 0.8°C over the past 100 years. Scientists predict that the earth's average temperature will increase by between 1.4 and 5.8°C by the year 2100.

Increase in global temperature will affect both the land and the ocean environments. The average temperature of the oceans has increased significantly in the past few decades, causing negative effects on marine life.

When the ocean water gets warm, the algae in the ocean tends to produce toxic oxygen compounds called superoxides which are damaging for the corals. Global warming is threatening the coral reefs to a great extent, and the fact is that if coral reefs are wiped off the planet, it will affect one third of planet's marine biodiversity, as well as other ecosystems related to the coral reefs directly or indirectly.

##### Extreme weather events

Extreme weather events include record-breaking high or low temperatures, floods or intense storms, droughts, heat waves, hurricanes and tornadoes, etc. These are effective measures of climate change and global warming.



### *Floods*

Scientists project that extreme weather events, such as heat waves, droughts, blizzards and rainstorms will continue to occur more often and with greater intensity due to global warming.

Other effects of extreme weather events include:

- higher or lower agricultural yields;
- melting of arctic ice and snowcaps. This causes landslides, flash floods and glacial lake overflow;
- extinction of some animal and plant species; and
- increase in the range of disease vectors, that is, organisms that cause diseases.

### Change in world's climate patterns

It is forecasted that global warming will cause climate patterns worldwide to experience significant changes. Climate change resulting from increasing temperatures will likely include changes in wind patterns, annual precipitation and seasonal temperature variations.

Climatic patterns in most parts of the world have already changed. Rains fall when least expected and at irregular intervals. This has greatly affected the timing of planting and harvesting activities. Sometimes the rains fall so heavily to cause floods, or too little leading to drought.

Most of the arable land that once used to be productive is slowly turning arid. With time, farmers will run short of the land for cultivation, a fact that will result in famine.

Because high levels of greenhouse gases in the atmosphere are likely to remain high for many years, these changes are expected to last for several decades or longer.

#### Rise in sea levels

Continued increase in the global temperature will cause the melting of ice caps in the poles and mountain glaciers. Melting polar ice and glaciers are expected to raise sea levels significantly. Global sea levels have risen about 8 inches since 1870 and the rate of increase is expected to accelerate in the coming years. If current trends continue, many coastal areas will eventually be flooded.

Scientists predict that by the year 2100 the sea level will raise by at least 25 m, leading to coastal flooding that will displace millions of people. Small islands in the Caribbean, South Pacific, Mediterranean and Indian Ocean will be totally covered by ocean waters.

#### Ocean acidification

As levels of atmospheric carbon dioxide increase, the oceans absorb some of it. This increases the acidity of seawater. Since the Industrial Revolution began in the early 1700s, the acidity of the oceans has increased about 25%.

Because acids dissolve calcium carbonate, seawater that is more acidic has a drastic effect on organisms with shells made of calcium carbonate, such as corals, mollusks, shellfish and plankton. The acid water is likely to dissolve the carbonaceous shells, thus endangering the lives of these sea creatures. Change in ocean acidity will also affect fish and other aquatic animals and plants.

If current ocean acidification trends continue, coral reefs are expected to become increasingly rare in areas where they are now common.

#### Effects on plants and animals

The effects of global warming on the earth's ecosystems are expected to be profound and widespread. Many species of plants and animals are already moving their range northward or to higher altitudes as a result of warming temperatures. Additionally, migratory birds and insects

are now arriving in their summer feeding and nesting grounds several days or weeks earlier than they did in the 20th century.

Warmer temperatures will also expand the range of many disease-causing pathogens that were once confined to tropical and subtropical areas, killing off plant and animal species that formerly were protected from disease.

These and other impacts of global warming, if left unchecked, will likely contribute to the disappearance of up to one-half of the earth's plants and one-third of animals from their current range by 2050.

#### Effects on humans

As dramatic as the effects of climate change are expected to be on the natural world, the projected changes to human society may be even more devastating.

Agricultural systems will likely be affected badly. Though growing seasons in some areas will expand, the combined impacts of drought, severe weather, lack of snowmelt, greater number and diversity of pests, lower groundwater tables and a loss of arable land could cause severe crop failures and livestock shortages worldwide.

This loss of food security might, in turn, create havoc in international food markets and could spark famines, food riots, political instability and civil unrest worldwide.

The effect of global warming on human health is also expected to be serious. An increase in mosquito-borne diseases like malaria and dengue fever, as well as a rise in cases of chronic conditions like asthma, are already occurring, most likely as a direct result of global warming.

# MAP WORK

## The Concept of a Map

*Define the concept of a map*

A map is a representation of an area of the earth's surface on a flat surface such as paper, wood, board, card, plastic, cloth or some other material.

The information given in a map is shown by conventional signs and symbols which are interpreted by the use of the "key". A map shows important natural and man-made features. Some maps show distributions like rainfall, temperature, air pressure and population. On a map, lines of longitude and latitude are marked to show the position of different areas.

## Types of maps

There are many different types of maps, which are generally classified according to the features they represent. Most of these maps are grouped into two major types:

- a. Topographic maps
- b. Statistical or distribution maps

Topographic maps

Topographic maps are maps that are used to show selected physical and human features of a given area. These maps show:

**Location:** The geographic location in a map may be shown using:

- a. compass bearing;
- b. grid reference;
- c. latitudes and longitudes;
- d. political and administrative boundaries; or

e. use of place names.

**Landscape:** Some of the landscape features shown on a topographic map are mountains, hills, plains, lakes, rivers and shape of coastlines. Relief maps show distribution of relief features such as hills, mountains, valleys and depressions.

**Cultural features:** Some of the cultural features or artificial features are roads, railways, cities, towns, dams and other structures built by man.

#### Uses of topographic maps

1. Topographic maps are useful for describing features of the earth's surface.
2. They are used to show the direction. People use maps to reach their destination. That is, they show which direction to go and how far to go.
3. Town planners use maps to plan the best use of land.
4. Road builders use maps to design new roads.
5. Farmers use maps to plan the best use of their farmlands.
6. Maps are essential to any field of study.
7. They provide much information on the nature and distribution of geographical phenomena e.g. settlement, population distribution, etc.

#### Statistical or distribution maps

These maps show such geographical phenomena as distribution of rainfall, temperature, pressure, vegetation, crops, minerals and many other phenomena. The commonly used statistical or distribution maps are Atlas maps. Atlas maps are usually drawn to scale. They represent a large area of the ground on a small space of paper. Maps of this nature are used to show various geographical aspects:

- a. Population maps show distribution of people and settlements e.g. towns and cities.
- b. Vegetation maps show the distribution of vegetation, e.g. forests, bushes and grasslands.

- c. Political maps show political administrative divisions e.g. countries, regions provinces and districts.
- d. Climatic maps show information on elements of climate such as rainfall, temperature and winds.
- e. Economic maps show the distribution of various human activities, e.g. farming, tourism, transport and mining.
- f. Travel maps show the location of places and distribution of hotels, camping sites, historical sites and other interesting places.

#### Characteristics of atlas maps

- a. They are drawn to scale.
- b. They show whole countries, continents or even the world on a single sheet of paper or page.
- c. They show generalized information. They do not include or show a great amount of detail as shown in topographic maps.
- d. Atlas maps may include and show the distribution of many features such as crops, minerals, roads, railways, towns, relief, vegetation and many others. Such details may be shown by the use of colours, signs and symbols.
- e. Atlas maps are simple and easy to read and interpret. They are easy to draw or to reproduce.

#### Uses of statistical and distribution maps

- 1. They are useful for describing the distribution of many features found on the earth's surface or showing certain selected features such as physical, political, historical or economic features.
- 2. They are useful for showing generalized information on large or small areas.

The following are examples of the uses of statistical or distribution maps:



- a. Physical maps show the arrangement or distribution of mountains, hills, highlands, lowlands, rivers and so forth. (b) Political maps shown areas with their political and administrative boundaries.
- b. Climatic maps show the distribution of temperatures, rainfall, pressure, winds, climatic regions, etc.
- c. Historical maps show the distribution of historical places e.g. historical sites.
- d. Economic maps show the distribution of chief crops, animals, industries, roads, mines, etc.

## Components of a Map

### Components of a Map

*List all the components of a map*

These are basic prerequisites or qualities that any map should have. A map should have:

- a. a title, which tells what the map is about;
- b. a key which is used to interpret the signs and symbols found on a map;
- c. a margin which bounds the map;
- d. an indication of the north direction; and
- e. a scale for showing the relationship between the distance on the map and that on the ground.

Each of these components is discussed in detail below:

- **Title:** The title shows the topic or subject matter of the map. It gives the name of the area which the map represents or the features represented on that map. The name of the map enables the user to read and interpret the map easily.

- **Key:** A key is a list of symbols and signs with their meanings as used in the map. It appears in a box at one of the bottom corners of the map. When these symbols and signs are given in the key, it becomes easier to interpret a map and get accurate information from it.
- **North direction:** This is a sign which shows the north direction. The sign gives an indication of the direction towards the north. It is from this direction that other cardinal points and positional locations of different areas on a map can be identified.
- **Margin:** This is a frame which encloses the area covered by the map. The margin is useful in that it guides and limits the map users as they read maps.
- **Scale:** The scale of the map indicates the ratio between the map and ground distances. It enables the map readers to make accurate estimation of distances on the map as they would be measured on the ground.

### A Scale and Different Ways Used in Representing a Scale

*Define scale and identify different ways used in representing a scale*

A scale is a ratio between the distance on the map and the true distance on the earth's surface.

$$\text{Scale} = \frac{\text{distance on map}}{\text{Distance on the earth's surface}}$$

Maps drawn to scale show the exact proportionality between the distance on the ground and that on the map.

Map scales are very crucial because they enable the map readers to calculate actual distances and areas on the ground based on the scales shown on maps. It is not possible to estimate the actual distance between two points on a map or a particular area on a map without the use of the scale. Though every map should have the scale, sketch maps are usually not drawn to scale. Sketch maps are rough sketches drawn on a flat surface to represent a particular area on the ground.

### Types of scales

Map scales are classified on two bases. They are classified based on:

- a. the way they are expressed; and
- b. their size.

Classification of scales based on the way they are expressed based on this mode, map scales may be expressed in any of the following ways:

1. As a statement
2. As a representative fraction
3. As a linear scale

#### Statement scale

This is the map scale stated in words or it is a verbal scale. The scale may be stated as “one centimetre represents ten kilometres or 1 centimetre to 10 kilometres or 1 cm to 10 km.”

It should be noted that in all statement scales map distances are stated in centimetres and ground distances in kilometres. For example it is wrong to state “one centimetre represents five hundred metres. The correct statement is “one centimetre represents a half kilometre.”

#### Properties of statement scales

1. They are expressed as word or verbal statements
2. The scales bear specific units of measurement. Usually the units representing map distances are smaller than the actual ground distances, e.g. 1 cm represents 5 kilometres.
3. The word “represent” and “not equal to” or “equivalent to” is used when expressing statement scales. For instance, do not state “one centimetre is equal to one kilometre”. This statement is wrong because one centimetre on a map is not exactly equal to one kilometre on the ground but just a scaled representative of the stated distance. The distance on the map is just taken as a representative of but not equal to the distance on the ground. The statement above is correctly stated as “one centimetre represents one kilometre”.
4. The map distance always carries the digit 1 while that of the ground may be less than or equal to 1. For example 1 cm represents ? km, 1 cm represents 1 km.

#### Representative fraction (RF) scale

This is a type of scale which expresses the map distance as a fraction of the actual distance on the ground, for example, 1:10000 or 1/10000. This means that one unit on the map represents 10000 units on the ground.

#### Properties of RF scales

1. The scales are either expressed as a ratio or fraction and do not bear any units. The units may be deduced from the linear or statement scale shown on the map.
2. The top number (numerator) stands for the map distance and is always reduced to 1.
3. The bottom number (denominator) stands for the ground distance and is usually more than 1.

It is important to note that when assigning units of measurement to RF scales, both the numerator and the denominator should bear the same units, e.g. 1 cm: 100 cm. The units used in most scales are centimetres. So, in case the units are not given, assume the units are in centimetres.

#### **Example 1**

Consider a map with an RF scale of 1/10000 or 1:100000. A river on this particular map measures 5 cm. Calculate the actual ground length of the river.

#### Solution

Since 1 cm on the ground represents 100000 cm on the ground, then 5 cm will represent  $5 \times 100,000 \text{ cm} = 500,000 \text{ cm}$ . But  $1 \text{ km} = 100,000 \text{ cm}$ . then, the actual ground distance is  $500,000/100,000 = 5\text{km}$ .

#### Linear (graph) scale

A linear scale or line scale or graph scale is a line showing the distance on the map that represents a given distance on the ground. It is expressed as a short or long line sub-divided into smaller, equal units. The linear scale is commonly placed at the bottom of the map. There are two categories of linear scales: the short-line scale and the long-line scale.

A short line scale consists of a single, short line that represents the actual ground distance. To get the unit of measurement on the map, one has to measure the length of the line in centimetres.

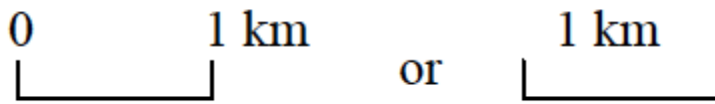

*Short-line scale*

A long line-scale consists of a long line that is sub-divided into several equal parts. It has two sections: the primary section and the secondary section.

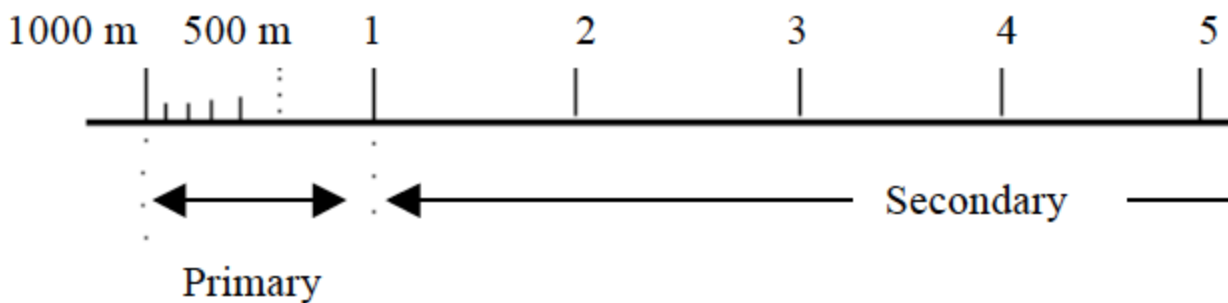

*Linear scale*

Properties of linear scales

1. The scales are expressed graphically in the form of a line.
2. They show the specific units of measurement.
3. They give a direct measure of the distance on the ground represented by the corresponding distance on the map.
4. The scale has the advantage of remaining the same even after the map is reduced or enlarged.

Classification of scales based on their sizes

Based on sizes, the scales are classified into three categories:

1. Small scales
2. Medium scales
3. Large scales

### Small scale

A map drawn using a small scale is called a small-scale map. A small-scale map has the following characteristics:

1. It represents a large area of the earth's surface on a piece of paper.
2. The features on a small scale map appear crowded and closer to each other than they really are. As a result, they are not seen clearly.
3. The map shows fewer details as it covers a large area on a piece of paper e.g. an atlas map of the world, Africa or Tanzania. It only gives a general picture of the area represented.

Examples of small scales are: 1:10,000,000 or 1 cm:100 km; 1:1,000,000 or 1 cm:10 km

### Medium scale

This is a scale ranging between a small scale and a large scale.

Examples of medium scales are: 1:500,000 or 1 cm:5 km; 1:250,000 or 1 cm:2.5 km

### Large scale

A map drawn using a large scale is called a large-scale map. A large-scale map has the following properties:

1. The map shows many details of a small area on a piece of paper, e.g. a map drawn to represent a small area such as a town, a certain location or village etc. Therefore, more features can be represented on a large scale map.
2. The map appears large in size though it represents a small part of the earth's surface.
3. The features on the map are large in size, so they can be seen quite clearly.

Examples of large scales are: 1:50,000 or 1cm:.0.5km; 1:25,000 or 1cm:.0.25km

## Difference between Signs and Symbols

*Distinguish and explain signs from symbols*













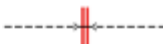

The natural and artificial landscape features are represented on maps by means of symbols and signs. Symbols and signs are the alphabet or language of maps. As symbols and signs are

important in giving information on a map they should have the following qualities. They should be.











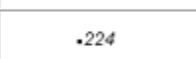

- a. Easy to read;
- b. Easy to understand;
- c. Easy to interpret; and
- d. Correctly and clearly shown and presented on any map.

Symbols and signs are commonly shown at the key or reference or legend of the map. With the aid of a key, reference or legend we can read and interpret a map. Symbols that are used in maps usually look like the natural and artificial features they represent. Signs usually do not look like the features they represent. Also most of the symbols are pictorial while most signs are not.













The symbols and signs used on maps are used to improve the appearance and readability of the map. Various symbols are used to depict features such as buildings, mines, forests, water bodies, farmlands, etc.

| Feature Name                     | Symbol/Sign   |
|----------------------------------|---|
| Bridge                           |    |
| Bridge; swing, draw, lift        |    |
| Footbridge                       |    |
| Ship anchorage; Ship base        |    |
| Falls                            |    |
| Rapids                           |    |
| Direction of flow arrow          |    |
| Dry river bed                    |    |
| Stream - intermittent            |    |
| Sand in water or foreshore flats |    |
| Rocky ledge, reef                |    |
| Flooded area                     |    |
| Marsh, muskeg                    |    |
| Swamp                            |   |
| Well, water or brine; Spring     |  |



|   |   |
|---|---|
| Rocks in water or small islands                     |    |
| Water elevation                                     |    |
| Horizontal control point; Bench mark with elevation |    |
| Precise elevation                                   |    |
| Contours; index, intermediate                       |    |
| Depression contours                                 |    |
| Cliff or escarpment                                 |    |
| Sand  |    |
| Moraine   |    |
| Quarry  |    |
| Cave  |    |
| Wooded area   |    |
| Orchard   |   |
| Vineyard  |  |

|                    |   |
|--------------------|---|
| Sports track       |  |
| Swimming pool      |  |
| Stadium            |  |
| Golf course        |  |
| Golf driving range |  |

|  |   |
|--|---|
| Campground; Picnic site                        |  |
| Ski area, ski jump                             |  |
| Electric facility                              |  |
| School; Fire station; Police station           |  |
| Church; Non-Christian place of worship; Shrine |  |
| Building                                       |  |
| Service centre                                 |  |
| Customs post                                   |  |
| Coast Guard station                            |  |
| Cemetery                                       |  |
| Ruins  |  |
| Fort   |  |
| Airfield, position approximate                 |  |

*Symbols and signs often used in maps*

## Quantitative Information on Maps

### The Distance on the Map and Converting to the Actual Ground by Using Scale

*Measure the distance on the map and convert to the actual ground by using scale*

One of the many tasks that a map reader might encounter when reading maps is to take measurements. Measurements on maps involve:

- a. measurement of distances; and
- b. calculation of areas on maps.

The conversion of map distances and areas into actual ground distances and areas requires the application of scales. A distance is the length between two specified points on a map.

## Measurement of distances on maps

Distances on maps can either be straight or curved (bent). A straight or regular distance is one that has no bends or curves while a curved (or irregular) distance is the one with bends or curves.

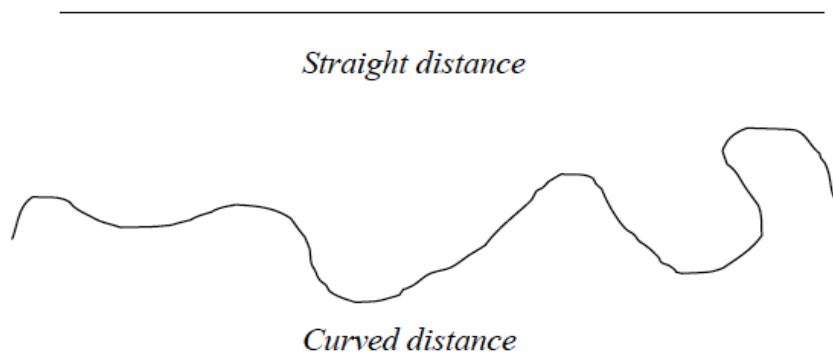

#### Tools for measuring distances

There are three main tools that are used for measuring distances on maps. These are:

1. a long, thin string or thread;
2. a piece of paper; and
3. a pair of dividers.

#### Measurement of distance using a thread or string

A long, thin string such as sewing thread can be used to measure a stretch of many curves or bends. This is the commonest method used by geography students to estimate distances on maps. This method is also used to estimate straight distances.

#### Procedures

- Identify the distance to be measured on the map (e.g. a river, road, railway line, etc) and mark its two ends with a sharp pencil. Mark one end as A and the other as B.

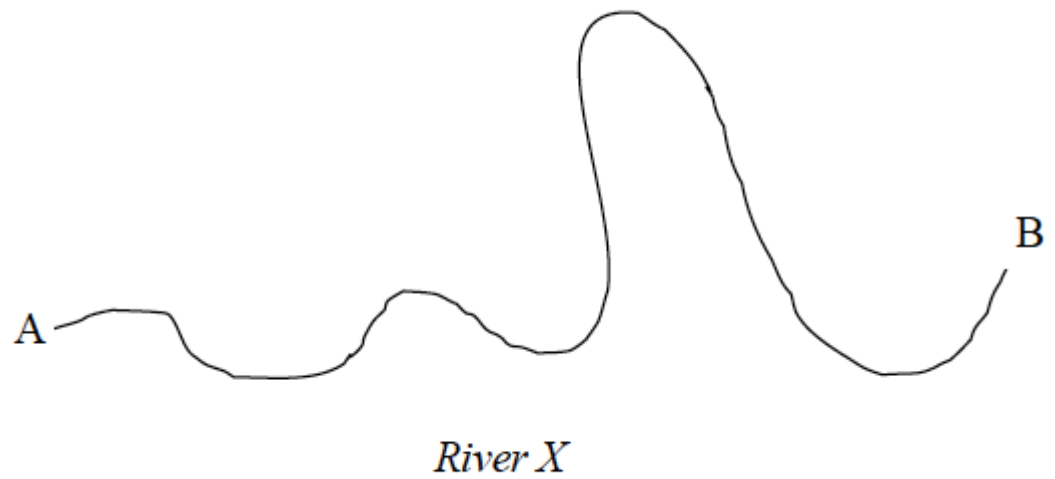

- Starting from one end of the string, trace the route (river, road, etc) with a string as shown in the figure below:

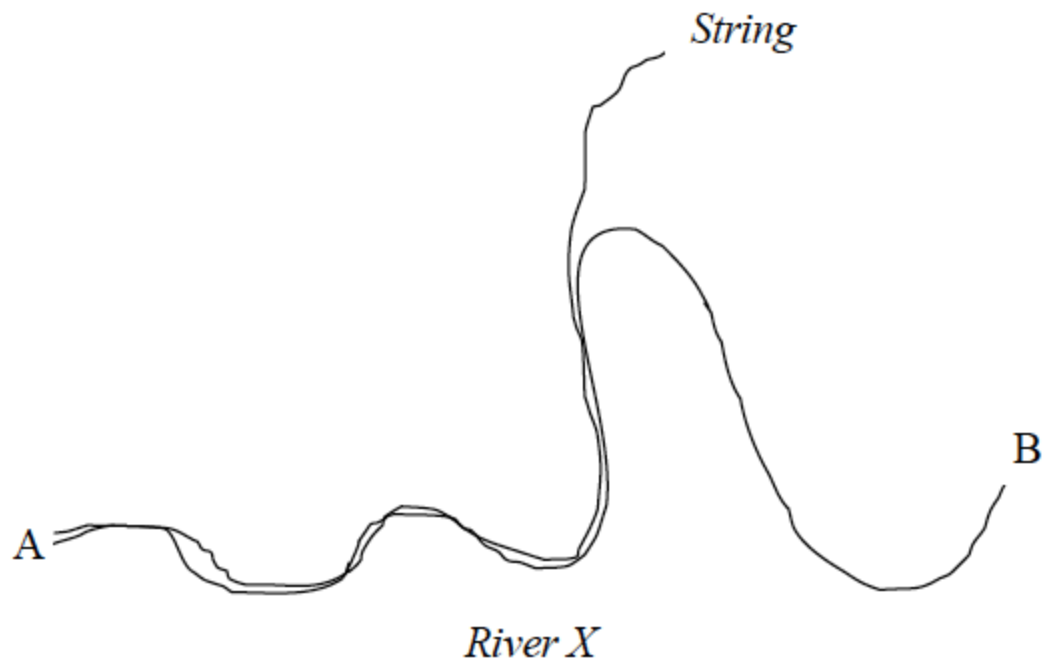

- Mark the string with an ink at point B.
- Using a ruler or linear scale, measure the length of the string between point A and B and estimate the actual distance on the ground using the scale of the map provided.

## Example 2

If the length of the section of the string between A and B is 20 cm and the scale of the map is one centimetre to one kilometre, then the length of the route on the ground is 20 km.

Measurement of distances using a piece of paper

A piece of paper can also be used to measure straight and irregular (curved, bent) distances

Measuring straight distances

Procedures

- Locate the distance to be measured on the map and mark its two ends as A and B using a sharp pencil.
- Take a piece of paper, fold it to form a straight edge and lay the edge along the line AB and mark the exact length of the line on the edge of the paper as shown in the figure below.

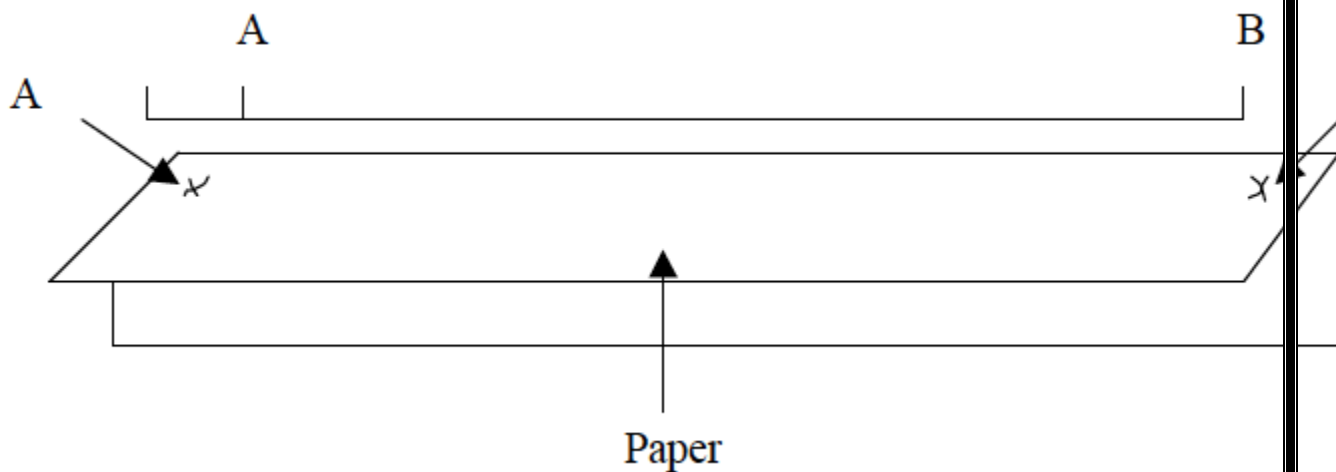

- Transfer the paper to a linear scale (or ruler) as indicated in the figure below so that the left hand mark (A) is on 0 (zero).

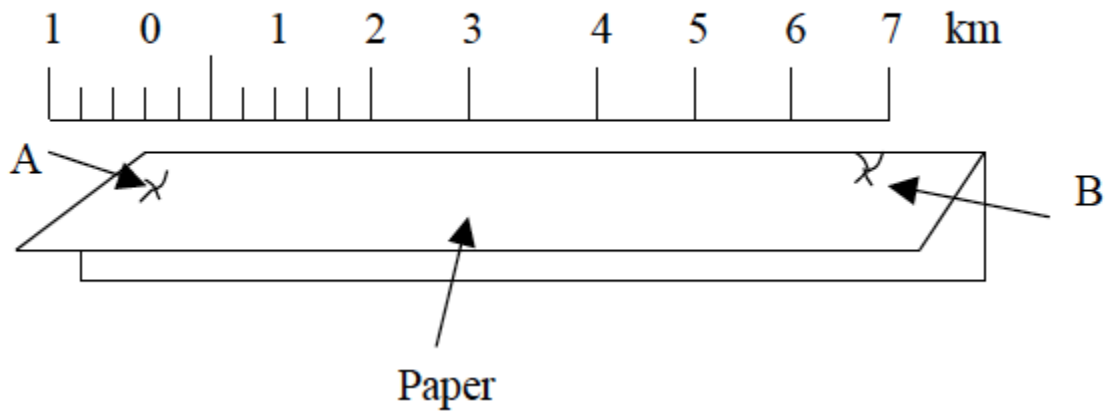

- Use the provided scale to estimate the actual ground distance.

Measuring irregular (curved) distances

Procedures

- Identify the length to be measured on the map. Use a sharp pencil to mark both ends A and B.
- Divide the route into sections which are more or less straight as shown in the figure below.

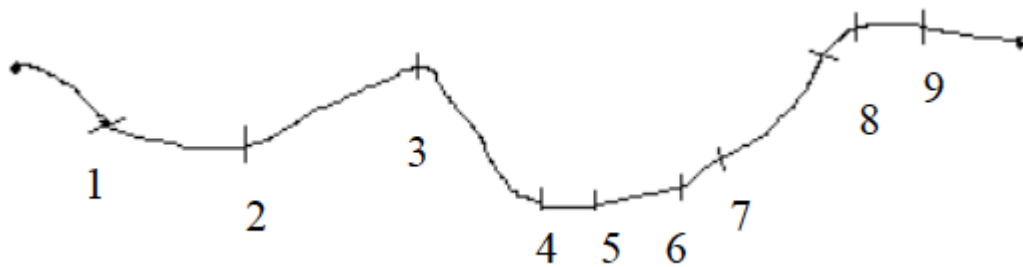

- Lay the straight edge of the paper on the first straight section of the route. Mark with your pencil where the route bends (point 1).

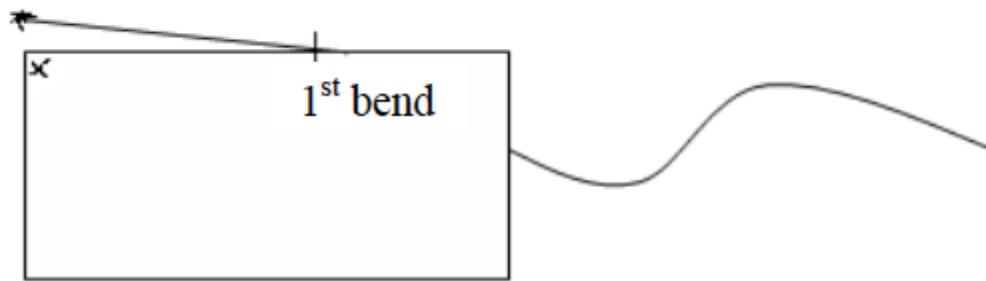

- Turn the paper so that the edge now lies along the second part of the route. Make sure that the mark you made is still on the point where the route bends. Now make another mark with your pencil at the bend (point 2).

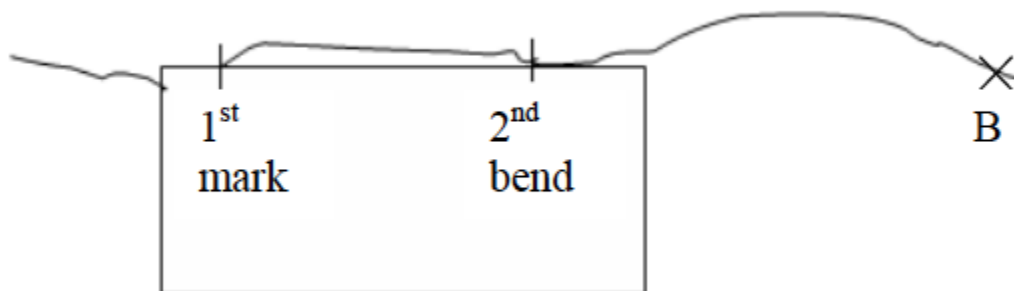

- Continue shifting the paper and marking the other distances between the points on the route.
- Remove the marked paper, and using a ruler, measure from where you started to the last mark on the paper. If this distance is 20 cm and the scale is 1 cm to 1 km, then the distance of the route between A and B is 20 km.

Measuring distances using a pair of dividers

Measuring straight distances procedures

1. Locate the distance to be measured on the map and mark its two ends using a pencil.
2. Use a pair of dividers to measure the distance between the two end points on the map.
3. If the distance is longer than the length of the dividers even when fully stretched measure the distance in sections and then sum up the lengths of all sections to get the total length.

- Place the divider on the linear scale and read the distance. Then use the scale to convert the obtained map distance into the actual ground distance.

Measuring irregular (curved or bent) distances

- Division method
- Stepping method

Division method

Procedures

- Divide the river, road, railway, etc into many, short straight distances.
- Open your dividers and measure all distances as shown in the figure below.
- Add up the map lengths of all sections along the route.
- Use the linear scale to get the actual ground length from the sum obtained in (iii) above. The length of the route is equal to the sum of all sections, divisions or short distances.

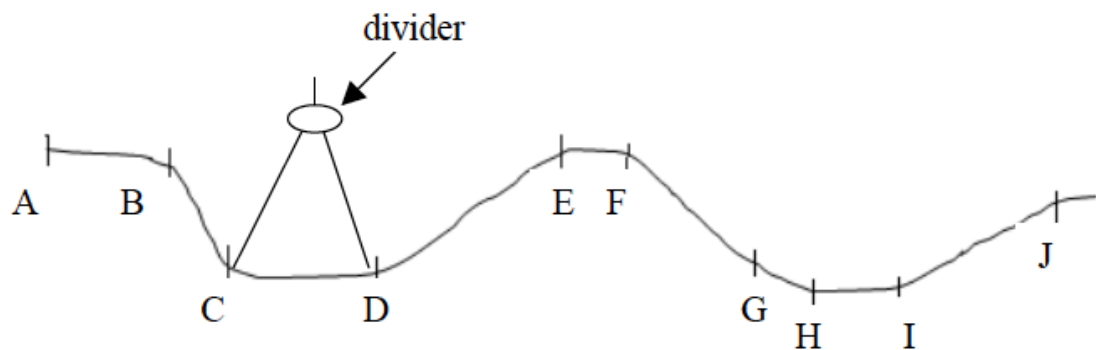

*Division method*

Add up all the measurements:  $AB = 1 \text{ km}$ ;  $BC = 1 \text{ km}$ ;  $CD = 1 \text{ km}$ ;  $DE = 2 \text{ km}$ ;  $EF = 0.5 \text{ km}$ ;  $FG = 2 \text{ km}$ ;  $GH = 0.5 \text{ km}$ ;  $HI = 1 \text{ km}$ ;  $IJ = 2 \text{ km}$  = Total length = 10 km.

Stepping method

- Open and set the pair of dividers to a known distance by using the linear scale e.g. quarter or half a kilometre as shown in the figure below.





### *Stepping method*

- Follow the river, road or line by stepping along it using the set dividers.
- Add up the number of steps and multiply by quarter or half a kilometre (depending on the set length).

#### **Example 3**

Suppose number of steps when the divider is opened to a quarter kilometres wide is 20 and when it is a half, kilometre is 10. Then, the length of the route is:

$$10 \times ? = 5 \text{ or } 20 \times ? = 5 \text{ kilometres}$$

Note that if the distance of the last step is less than the set distance of the dividers, measure it separately and estimate its distance on the linear scale. Add up this distance to the total distance from the steps to get the full distance of the route (river, road or line).

### **Areas of Regular and Irregular Figures**

*Calculate areas of regular and irregular figures*

The figures whose areas are to be calculated on maps can either be regular or irregular

### **Calculating areas of irregular shapes**

Features with regular shapes on maps are rectangular, triangular, square or circular. Finding the areas of such figures is simple. Mathematical formulae are used to calculate their areas. However, it is not common to find regular features on maps.

Calculating areas of different regular shapes

1. Triangles =  $L \times W$ , where  $L$  = length and  $W$  = width.

2. Squares =  $L^2$ , where  $L$  = length of the side of a square.
3. Triangles =  $\frac{1}{2}bh$ , where  $b$  = length of the base and  $h$  = length of the height.
4. Circle =  $\pi r^2$  or  $\frac{\pi D^2}{4}$ , where  $r$  = radius,  $D$  = diameter and  $\pi = 3.14$  or  $\frac{22}{7}$

**Calculating areas of irregular shapes:** Features with irregular shapes are very common on maps. These may include shapes of lakes, forests, plantations, settlements, marshy land, etc.

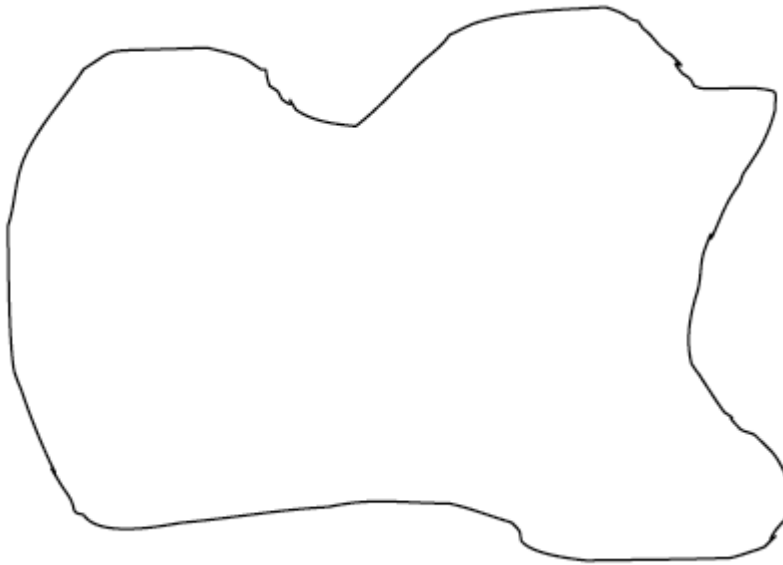

*An irregular shape*

There are three methods used to calculate areas of irregular shapes. These are the:

- a. division method;
- b. tracing method; and
- c. grid square method.

Division method

In this method, the area to be measured is divided into rectangles or squares and triangles or into several strips of the same length and width. Then, the area of each resulting figure is calculated using mathematical formula and summed up to get the total area.

1. Divide the whole area into rectangles, squares or triangles.

2. Calculate the areas of the rectangles, squares and triangles using mathematical formulae.
3. Sum up individual areas to get the total area Remember that the area should be in the same units as the map scale.

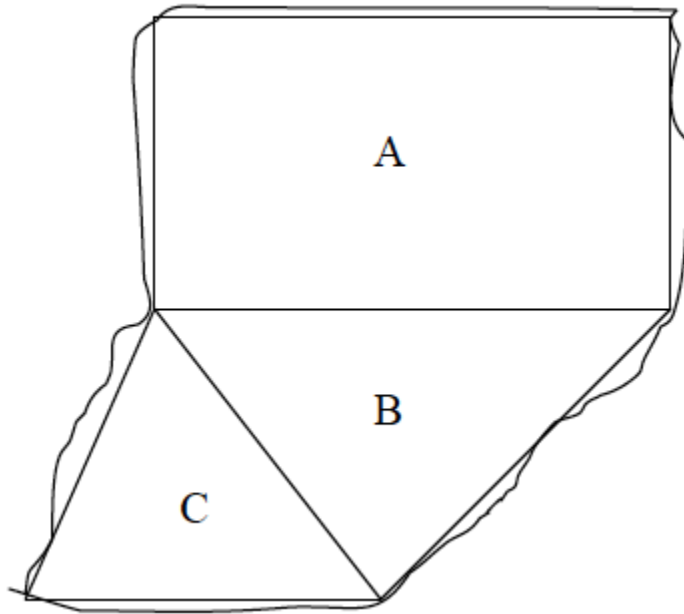

#### Example 4

The area above is divided into three figures A, B and C. The area of the three resulting figures is calculated as follows:

*Rectangle A:* Area =  $L \times W = 10 \times 5 = 50 \text{ km}^2$

*Triangle B:* Area =  $\frac{1}{2}bh = \frac{1}{2} \times 6 \times 4 = 12 \text{ km}^2$

*Triangle C:* Area =  $\frac{1}{2}bh = \frac{1}{2} \times 4 \times 3 = 6 \text{ km}^2$

**Total area** =  $A + B + C = 50 + 12 + 6 = 68 \text{ km}^2$

Division of the area into strips

The stripping method involves dividing the area into strips and then calculating the area of each strip separately. The total area is obtained by summing up the areas of all rectangular strips.

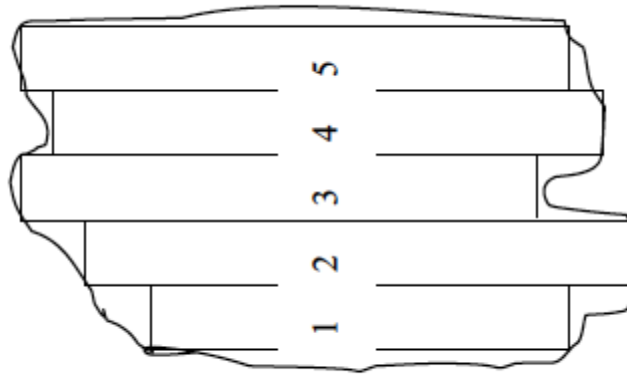

Scale: 1cm = 1 km

### Procedures

1. Divide the area into uniform rectangular strips.
2. Calculate the area of each rectangular strip separately. Remember that the areas of the strips should be in the same units as the scale of the map.
3. Add up the area of each strip to get the total area.

Area = sum of the areas of all individual strips = area of 1 + 2 + 3 + 4 + 5

### Tracing method

1. Trace off the outline (boundary) of the figure to be measured onto a tracing paper (graph paper) or ordinary tracing paper and transfer the outline onto a squared paper.
2. Tick and count all complete squares and sum up their areas. Remember that each full square measures 1 cm x 1 cm.
3. Mark all incomplete squares with crosses.
4. Count all incomplete squares and divide the sum by 2 to get the number of complete squares.
5. Add up the squares in (iii) and (iv) to get the total number of squares covering the area of the figure to be estimated.

6. Using the scale provided, find the area of one square in order to obtain the actual area that would be covered on the ground. Note that the area that you calculate is the approximate area.

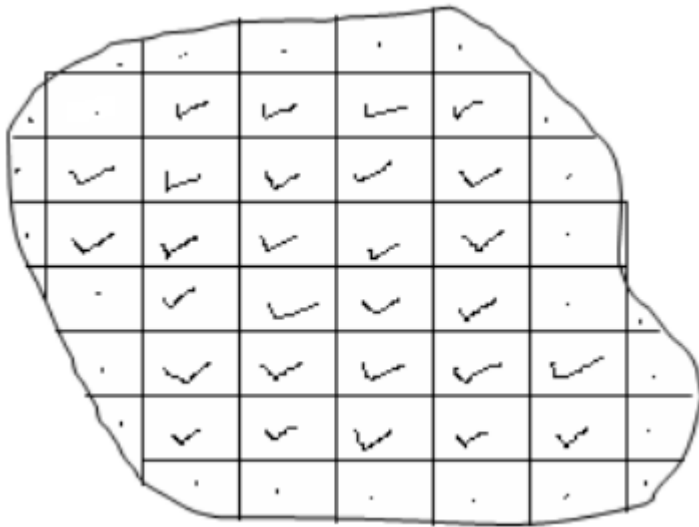

According to the figure above, the number of complete squares is 28. The number of incomplete squares is 25. To get the complete squares, we divide 25 by 2, i.e.,  $25 \div 2 = 12.5$

Hence the total number of complete squares =  $28 + 12.5 = 40.5$ . This is the same as  $40.5 \text{ cm}^2$ .

Assume that the scale of the map is 1:50,000. Then, the area of 1cm by 1cm on the ground is  $0.5 \times 0.5 \text{ km} = 0.25 \text{ km}^2$

Therefore, the total actual ground area of the irregular shape is calculated thus: Area =  $40.5 \times 0.25 = 10.125 \text{ km}^2$ .

Remember that if you don't have the tracing paper you can draw the squares straight on the map using the following procedures:

1. Mark by a pencil the margin of area to be measured.
2. Using the grid reference lines as your guidelines, draw the squares with faint pencil lines across the area. If there are no grid lines make sure you draw right angled squares across the figure.
3. Mark your full squares and half squares and follow the above tracing method procedures for calculating the area.

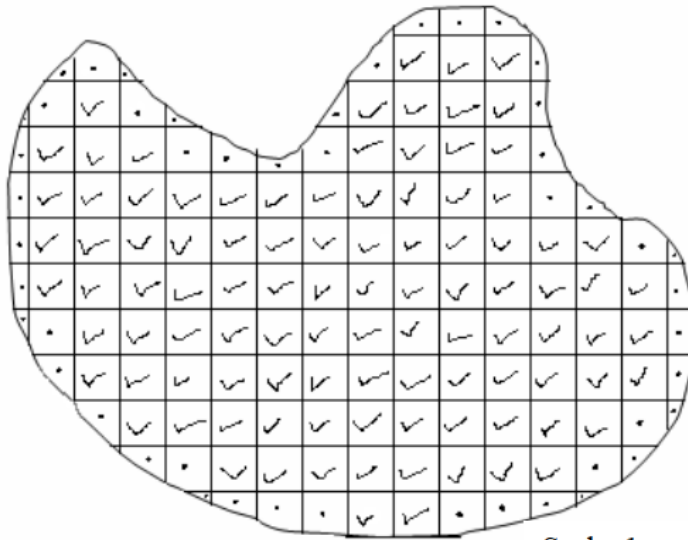

Scale: 1 cm = 1 km

Number of full squares = 100

Number of half squares = 48

**TOTAL area = 124 sq. km**

The grid square method

If the map provided has grid lines, the grid square method can be used to calculate the area on the map. The grid squares formed by the lines are used in this case. For example, in a topographical map of scale 1:50,000 the distance between two successive grid lines is 2 cm. This length is equivalent to 1 km on the ground. Therefore, every grid square on a 1:50,000 map represents 1 km<sup>2</sup> on the ground. Consider the diagram below:

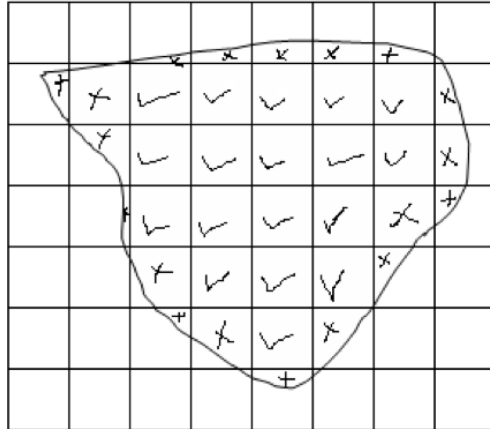

Number of full grid squares = 18  
 Number of half grid squares = 19  
**TOTAL area = 27.5 sq. km**

The procedures for calculating the area of a figure on a map with grid squares are similar to those used in the tracing method discussed previously in this chapter.

## Location of Position

*Identify location of position*

In map reading, position is a place where an object is situated on the earth's surface. The geographic position of a place may be shown by using:

1. Place names
2. Compass bearing
3. Latitude and longitude
4. Grid reference
5. Political and administrative boundaries

## Use of place names

Names of places on maps may be used to locate the position of an area or place. Names of places e.g. Morogoro, Tarime, Mbeya, etc are clearly marked and shown on maps.

Compass bearing

Many years ago it was discovered that a magnetized piece of iron or needle, if hung or allowed to swing freely, will always point to the same direction. This direction is called the North. It is from the north direction that we measure other directions, that is, East, West and South.

A compass is an instrument used to measure directions from the north. It consists of a free-swinging, magnetized needle which points to the north and south magnetic poles.

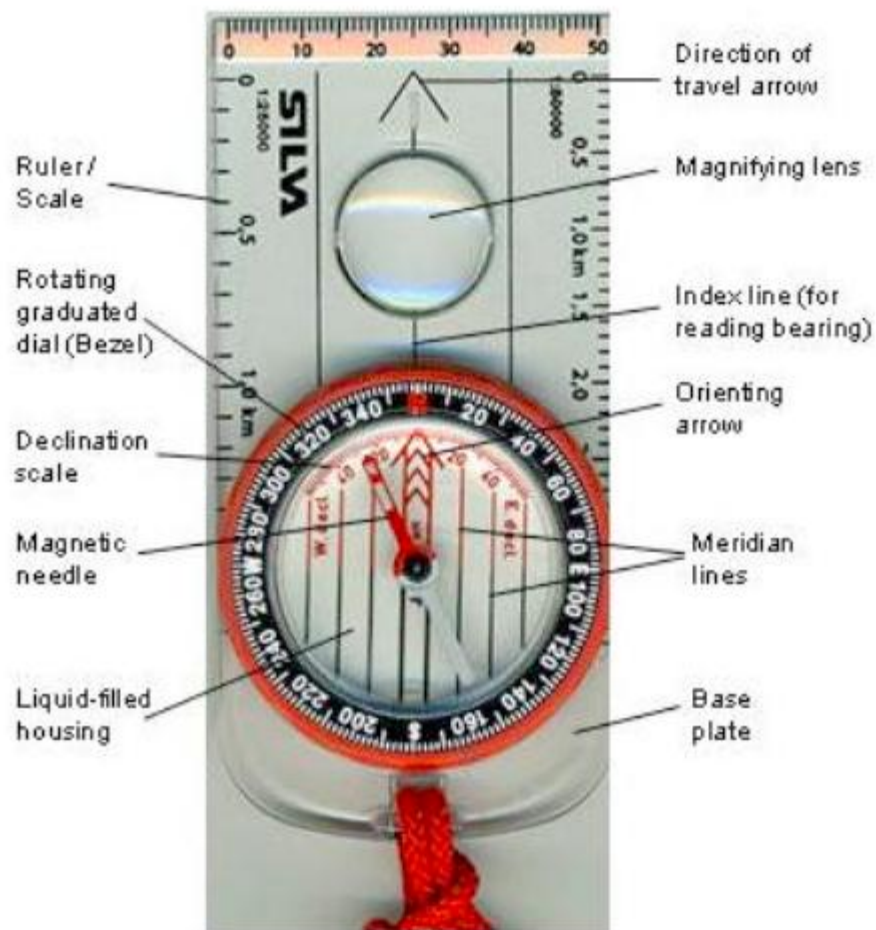

### *A compass*

The compass can be used to show directions in the following ways:

North direction

The north direction may be shown by using; Geographic or True North; Magnetic North and Grid North.



1. Geographic or True North is the direction towards the North Pole from any place on the earth's surface. It is always indicated by the north arrow. When reading directions on maps we usually use the True North.
2. Magnetic North is the direction to which the compass needle points. The magnetic North is some distance from the True North and also varies from year to year in relation to the True North.
3. The Grid North is the direction towards the north in those maps drawn to grid system.

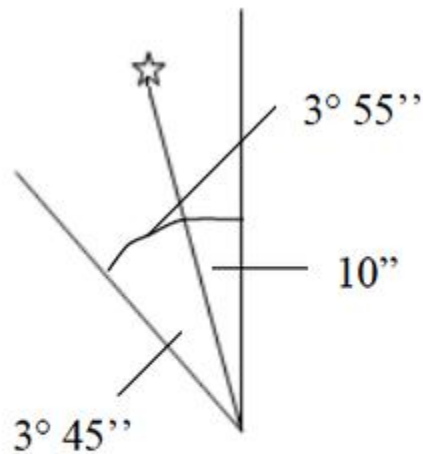

Magnetic declination as at  
January 1970  
Annual change: 1'

#### Compass directions

There are four major directions, bearings or cardinal points on maps with respect to a fixed point, be it true North or magnetic North. They are marked by 90°.

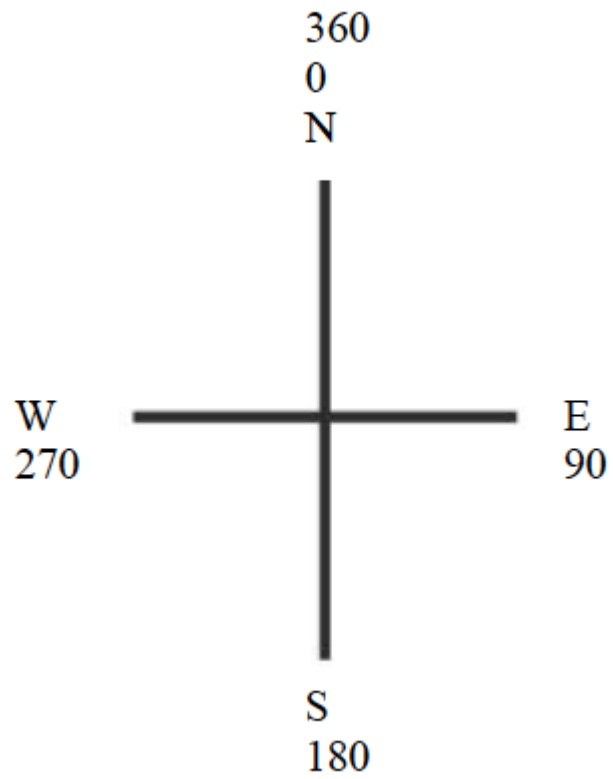

The four cardinal points can further be sub-divided into eight points of 45°

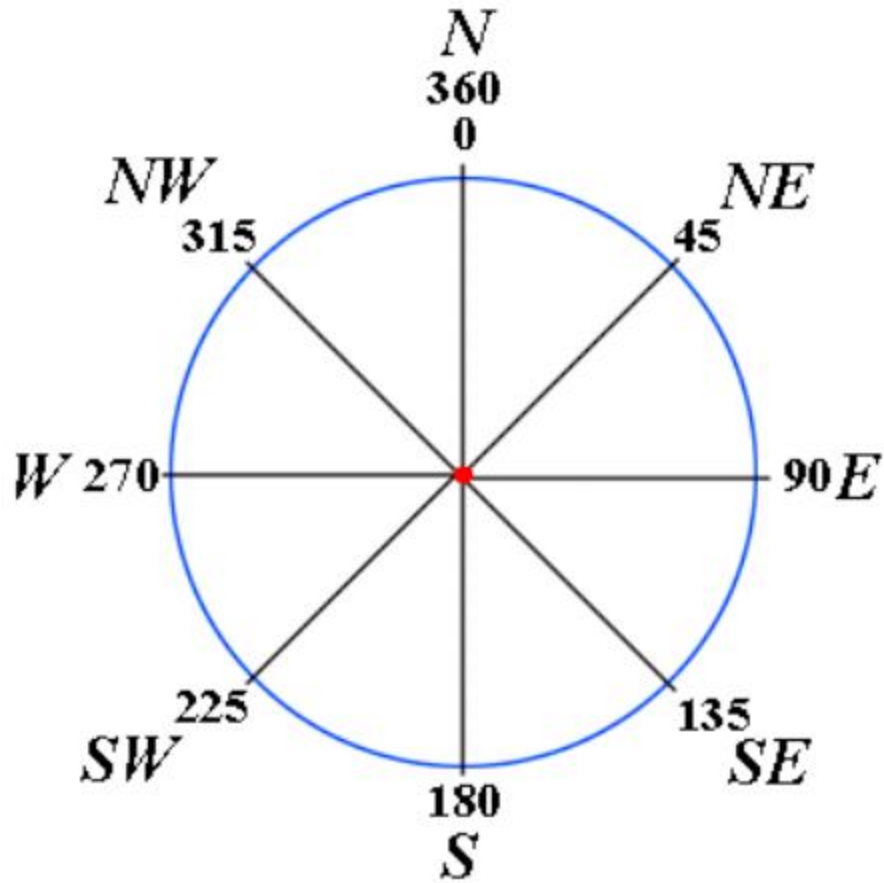

The eight points of a compass can further be sub-divided into sixteen points of 22.5°

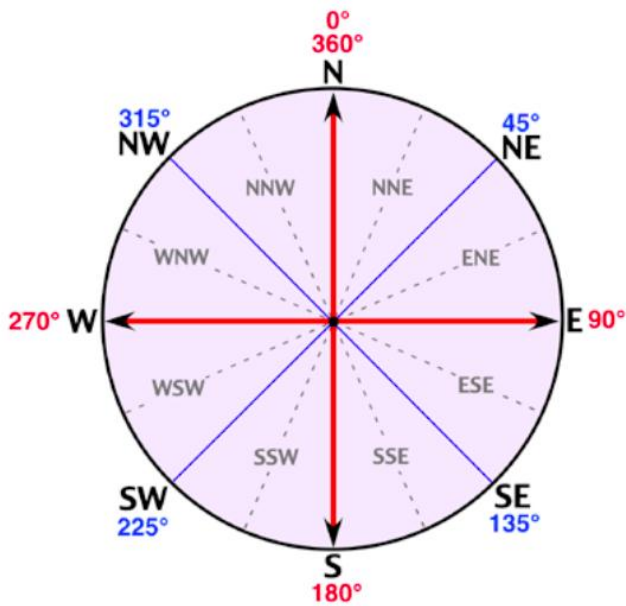

### Bearings of a compass

Compass bearing shows the direction of a point with respect to another point measured clockwise from 0° to 360°. Bearing is expressed in degrees which are further sub-divided into minutes and seconds.



### *Bearings of a compass*

#### Grid reference

A grid system is a pattern of horizontal and vertical lines forming squares of uniform sizes drawn on a map. Grid system is numbered East and North and is referred in terms of Easting and Northing.

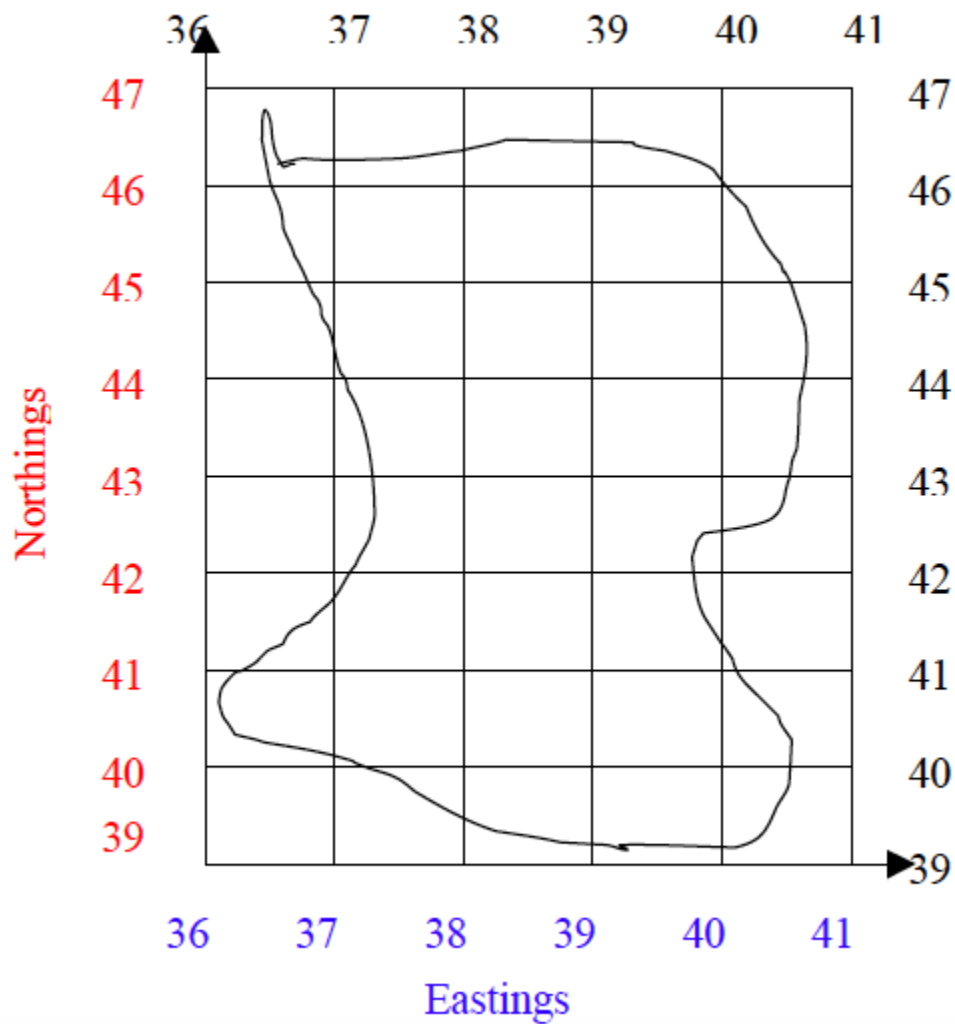

Grid lines are not lines of latitude and longitude, but are drawn to a definite distance apart, which varies according to the scale of the map and unit of measurement used in a map. The reading in a grid system is referred to as grid reference and is given in a six-figure number.

Using grid reference

- a. The full grid reference is given in a six-figure number.
- b. Easting – the eastward direction or reading are always given first.
- c. Northing – the northward direction or reading follows after the Easting. Example Easting = 351 Northing = 421 Full grid reference = 351421

d. When a place or point falls on the main gridlines or bisected by the grid line, add 0 to each reading Example A place is bisected by:- Easting =35 Northing = 40 The grid reference of a point will be 350400

e. When a place or point falls in the middle of a grid square, the grid square is sub-divided into ten equal squares or tenths. The grid reading or direction is given to the nearest tenths. Consider the point, A, in the figure below). Example See point B in the figure below. The point lies between the following grid reference: Easting = 35 Northing = 42

#### Procedures

1. Divide the grid square into tenth to locate the point or place. For example, point A in the figure below lies at:- Easting = 5 tenths Northing = 5 tenths
2. Read the easting adding the 5 tenth digit = 565
3. Read the nothing adding the 5 tenth digit =225
4. Full grid reference of the point is 565225

### Direction and Bearing of Object on Maps

#### *Find direction and bearing of object on maps*

The bearing of a place on a map can be found when the north is given. The North is usually an arrow sign pointing to the north.

#### **Example 5**

Find the bearing of point B from point A.

#### Procedures

1. Join points B and A with a straight line.
2. At point A, draw a line parallel to the north-south line.
3. Using a protractor, measure the angle B from the north towards line BA as shown below.

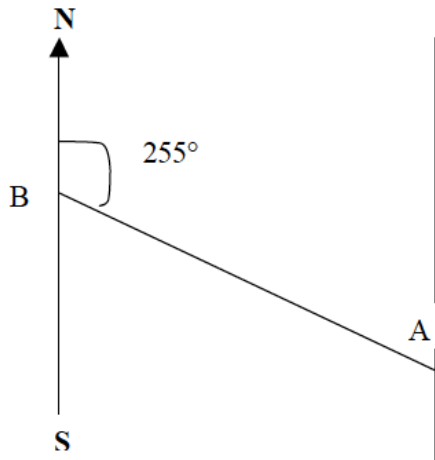

## Direction of a place

The direction of a place or point is its direction with respect to another point measured by using the points of the compass e.g. North, South, East and West.

### Example 6

Find the direction of point B from point A.

Procedures

1. Join points A and B with a straight line.
2. At point A, draw a line parallel to the north-south line or compass direction sign that is given on a map.
3. Draw a horizontal line at point A to get the East and West of the four points of the compass.
4. Find the direction of point B from A to the nearest point of the compass. The four, eight or sixteen points of a compass may be used.

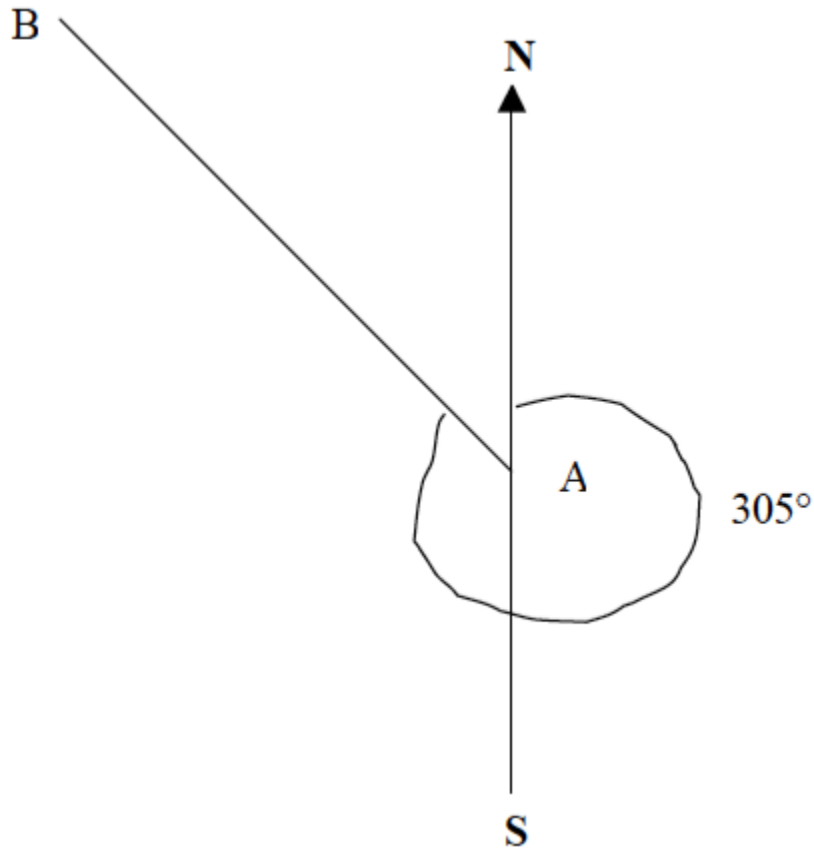

When finding angular bearing or direction of a compass, always use the “True North” which is given on the map.

## Uses of Maps

### Different Uses of Maps

*Describe different uses of maps*

Maps are important tools to a geographer. They are the crucial means of reading and communicating information about the location and spatial characteristics of the natural world.

Maps are not only important to geographers. They are used throughout the world by scientists, scholars, governments and the general public to meet environmental, economic, political and social needs. The following are some of the uses of maps:



1. Maps are important tools to geographers. They help geographers understand, in a visual way, important things about the surface of the earth. For example, maps help the geographers locate important features such as volcanoes; hilly and mountainous areas; dense forests; etc.
2. Maps are used to record and store information about the environment, the location of natural resources, capital assets and people. This is because the features change while map information does not change. As such, maps store information for future reference.
3. Maps allow us to convey information and findings that are difficult to express verbally. Thus, the maps make the studying and understanding of geography easier since they have pictorial characteristics
4. A map shows the relationship between and among features for example, a map clearly indicates the location of places, rivers, a network of roads, vegetation, etc.
5. Maps enable us to study the distribution of geographical phenomena such as water bodies, valleys, mountains, vegetation and other features. 6. Maps, especially those drawn to grid systems, give the location or position of a place or feature.
6. Maps may be used for estimating travel costs between two or more places. This may be done by estimating the distance to be covered (by using map scales) and then multiplying the distance by the cost per kilometre or mile to obtain the total travelling costs.
7. Climate maps provide crucial information about the climates of different parts of the world and how these climates influence daily human activities.